

# **BE** POWER EQUIPMENT



# OPERATION MANUAL

FIRE PUMPS  
WATER TRANSFER PUMPS  
ULTRALITES  
TRASH PUMPS  
POLY CHEMICAL PUMPS

OCTOBER 2023



Congratulations on your purchase of a high quality B.E. pump. All components have been designed and manufactured to give trouble free, reliable operation.

B.E. has developed over many years a strong reputation for world class innovation and quality that has enabled the product to be sold all throughout the world.

Keep this owners manual handy so you can refer to it at any time. Information and specifications included in this publication are valid at time of publication, however, B.E. reserves the right to discontinue or change specifications or design at any time without notice and without incurring any obligations.

This manual is accompanied with the appropriate engine manual.

4 TABLE OF CONTENTS

**INTRODUCTION**

5 USING THE OPERATORS MANUAL  
5 SUCTION AND DISCHARGE HOSE

**PRODUCT IDENTIFICATION**

6 IDENTIFICATION NUMBERS  
6 PRIMING

**SAFETY**

7-11 SAFETY RULES  
7-11 HAZARD SYMBOLS AND MEANINGS

**WATER PUMP COMPONENTS**

12 COMPONENT CHART

**ASSEMBLY**

13 CONNECT SUCTION HOSE TO PUMP  
13 ATTACH SUCTION HOSE TO STRAINER BASKET  
13-14 CONNECT DISCHARGE HOSE

**OPERATION**

15 WHAT IS "HEAD"  
15 MOVE WATER PUMP TO SAFE LOCATION  
16 PRIME THE WATER PUMP  
17 LOCATE STRAINER BASKET INTO WATER SOURCE

**STARTING THE WATER PUMP**

18-19 STARTING THE WATER PUMP

**STOPPING THE WATER PUMP**

20 STOPPING THE WATER PUMP  
20 DRAIN AND FLUSH WATER PUMP

**PUMP APPLICATIONS**

21 HOW TO CHOOSE A WATER PUMP  
22 TROUBLESHOOTING



**Attention: Read through the complete manual prior to the initial use of your water pump**

## **Using the Operator's manual**

The operating manual is an important part of your water pump and should be read thoroughly before initial use, and referred to often to make sure adequate safety and service concerns are being addressed.

Reading the owner's manual thoroughly will help avoid any personal injury or damage to your machine. By knowing how best to operate this machine you will be better positioned to show others who may also operate the unit.

This manual contains information for the complete range of BE water pumps, and is placed in order starting from the safety requirements to the operating functions of your machine. You can refer back to the manual at any time to help troubleshoot any specific operating functions, so store it with the machine at all times.

When installing an **BE self priming pump**, always remember that the closer the pump is placed to the source of supply the better the performance will be.

To ensure maximum capacity select a site that will permit the shortest and most direct suction piping and smallest vertical lift.

Set the pump on firm and level foundations with good drainage, in a area not subject to flooding.

## **Connecting the Suction Hose**

Use commercially available hose, hose connector and hose bands.

The suction hose must be of reinforced non collapsible construction, suction hose length should not be longer than necessary as the longer the suction hose, the less delivery performance of the pump. Self priming time is also proportional to suction hose length!

Strainer **MUST** always be used on the end of the suction hose to keep solids out of the pump.

**Check carefully to make sure there are no air leaks in the suction line** and that the rubber gaskets are in good condition. Any minute leak in the suction line will cause loss of suction prime

## **Connecting the Discharge Hose**

Use a commercially available hose, hose connector and hose bands. A large diameter hose is most efficient. Long, small diameter hoses will increase friction loss and reduce pump performance and adversely affect performance.

## **Record Identification Numbers**

### **Water Pump**

If you need to contact an Authorized Dealer or Customer Service line (02) 4577 2144 and email : sales@bargroup.com.au for information on servicing, always provide the product model and identification numbers.

You will need to locate the model and serial number for the machine and record the information in the places provided below.

**Date of Purchase:**

**Dealer Name:**

**Dealer Phone:**

## **Product Identification Numbers**

**Model Number:**

**Serial Number:**

### **Priming**

Remove the priming cap at the top of the delivery port. Fill pump body with water and refit priming cap tightly.

Open gate valve on delivery line if fitted, turn on engine and run at full speed during priming.

Allow up to 3 minutes to prime.

**Never attempt to operate pump without priming first.** Extended dry operation will destroy pump seal.

If unit has been run dry, stop the engine immediately, allow the pump to cool before adding priming water.

### **Hydraulic Shock**

If the water flow is suddenly terminated by closing a valve, without stopping the pump first, it can cause hydraulic shock. This can travel back to the pump causing serious damage. To prevent pump damage install a by-pass or safety relief valve.

# SAFETY

## Save these Instructions

### Safety Rules



This is the safety alert symbol. It is used to alert you to potential personal injury hazards. Obey all safety messages that follow this symbol to avoid possible injury or death.

The safety alert symbol (▲) is used with a signal word (DANGER, CAUTION, WARNING), a pictorial and/or a safety message to alert you to hazards.

**DANGER** indicates a hazard which, if not avoided, will result in death or serious injury.

**WARNING** indicates a hazard which, if not avoided, could result in death or serious injury.

**CAUTION** indicates a hazard which, if not avoided, might result in minor or moderate injury.

**NOTICE** indicates a situation that could result in equipment damage. Follow safety messages to avoid or reduce the risk of injury or death.

### Hazard Symbols and Meanings

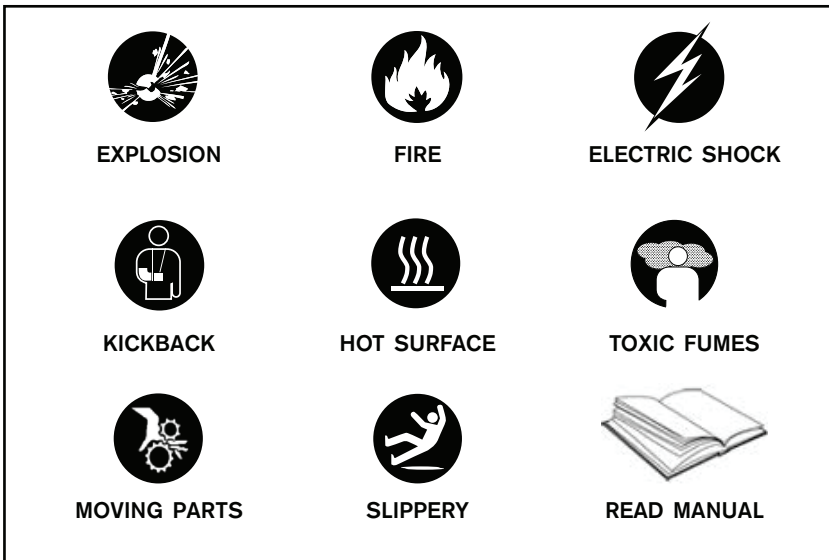

**⚠ WARNING**

Running engine gives off carbon monoxide, an odorless, colorless, poison gas.

Breathing carbon monoxide can cause headache, fatigue, dizziness, vomiting, confusion, seizures, nausea, fainting or death.

- Operate water pump **ONLY** outdoors.
- Keep exhaust gas from entering a confined area through windows, doors, ventilation intakes, or other openings.
- **DO NOT** start or run engine indoors or in an enclosed area, even if windows and doors are open.

**⚠ WARNING**

Use of water pump can create puddles and slippery surfaces.

- Operate water pump from a stable surface.
- The area should have adequate slopes and drainage to reduce the possibility of a fall due to slippery surfaces.

**⚠ WARNING**

Unintentional sparking can result in fire or electric shock.

**When Adjusting or Making Repairs to Your Water Pump**

- Disconnect the spark plug wire from the spark plug and place the wire where it cannot contact spark plug.

**When Testing for Engine Spark**

- Use approved spark plug tester.
- **DO NOT** check for spark with spark plug removed.



**⚠ WARNING**

Fuel and its vapors are extremely flammable and explosive.



Fire or explosion can cause severe burns or death.

**When Adding or Draining Fuel**

- Turn water pump OFF and let it cool at least 2 minutes before removing fuel cap. Loosen cap slowly to relieve pressure in tank.
- Fill or drain fuel tank outdoors.
- DO NOT overfill tank. Allow space for fuel expansion.
- If fuel spills, wait until it evaporates before starting engine.
- Keep fuel away from sparks, open flames, pilot lights, heat, and other ignition sources.
- DO NOT light a cigarette or smoke.

**When Starting Equipment**

- Ensure spark plug, muffler, fuel cap, and air cleaner are in place.
- DO NOT crank engine with spark plug removed.

**When Operating Equipment**

- DO NOT pump flammable liquids, such as fuel or fuel oils.
- This water pump is not for use in mobile equipment or marine applications.
- DO NOT tip engine or equipment at angle which causes fuel to spill.
- Secure water pump. Loads from hoses may cause tipover.

**When Transporting or Repairing Equipment**

- Transport/repair with fuel tank EMPTY or with fuel shutoff valve OFF.
- Disconnect spark plug wire.

**When Storing Fuel or Equipment with Fuel in Tank**

- Store away from furnaces, stoves, water heaters, clothes dryers, or other appliances that have pilot light or other ignition source because they can ignite fuel vapors.

**⚠ WARNING**

Starter cord kickback (rapid retraction) can result in bodily injury. Kickback will pull hand and arm toward engine faster than you can let go.

Broken bones, fractures, bruises, or sprains could result.

Keep hands and body clear from discharge of pump.

- When starting engine, pull cord slowly until resistance is felt and then pull rapidly to avoid kickback.
- Secure discharge hose to avoid whipping.

**⚠ WARNING**

Contact with muffler area can result in serious burns.

Exhaust heat/gases can ignite combustibles, structures or damage fuel tank causing a fire.

- DO NOT touch hot parts and AVOID hot exhaust gases.
- Allow equipment to cool before touching.
- Keep at least 5 feet (1.5 m) of clearance on all sides of pressure washer including overhead.

**⚠ WARNING**

Starter and other rotating parts can entangle hands, hair, clothing, or accessories.

- NEVER place hands or body parts inside of running pump or hoses.
- Never operate water pump without protective housing or covers.
- DO NOT wear loose clothing or anything that may be caught in the starter or other rotating parts.
- Tie up long hair and remove jewelry.

## CAUTION

Excessively high operating speeds increase risk of injury and damage to water pump.

Excessively low speeds impose a heavy load.

- DO NOT tamper with the governed speed.
- DO NOT modify the water pump.
- DO NOT allow unqualified persons or children to operate or service water pump.

## NOTICE

Improper treatment of water pump can damage it and shorten its life.

- If you have questions about intended use, ask dealer or contact nearest authorized dealer.
- Be sure pump chamber is filled with water before starting the engine. Never run pump without priming.
- Use a non-collapseable hose on the suction side of the hose.
- Use water pump only for intended uses.
- Pumping sea water, beverages, acids, chemical solutions, or any other liquid that promotes corrosion can damage the pump.
- Ensure all connections are air tight.
- DO NOT obstruct the suction or discharge hose in any way.
- NEVER operate pump without strainer basket connected to end of suction hose.
- NEVER allow vehicles to drive over hoses. If a hose must be positioned across a roadway, use planking on each side of hose to allow vehicles to pass over without obstructing or collapsing hose.
- Anchor pump to avoid equipment movement.
- Keep equipment away from edge of river or lake where it could cause the bank to collapse.
- DO NOT insert any objects through cooling slots.
- NEVER operate units with broken or missing parts, or without protective housing or covers.
- DO NOT by-pass any safety device on this machine.
- NEVER move machine by pulling on hoses. Use frame on unit.
- Check fuel system for leaks or signs of deterioration, such as chafed or spongy hose, loose or missing clamps, or damaged tank or cap. Correct all defects before operating water pump.



Read this operator's manual and safety rules before operating your water pump.

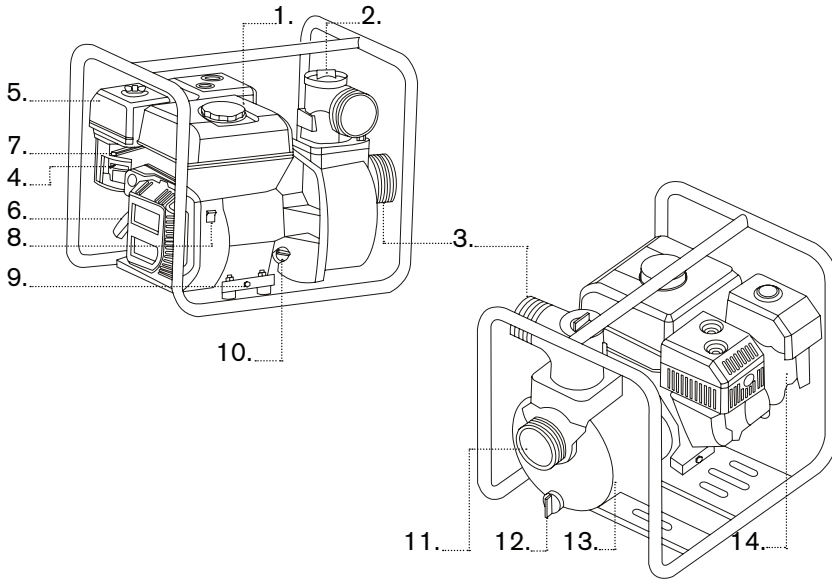

- 1. Fuel Tank** Fill tank with regular unleaded fuel. Always leave room for fuel expansion.
- 2. Priming Plug** Fill pump with water here to prime pump before starting.
- 3. Discharge Outlet** Connect discharge hose here.
- 4. Choke Lever** Prepares a cold engine for starting.
- 5. Air Cleaner** Protects engine by filtering dust and debris out of intake air.
- 6. Recoil Starter** Used for starting the engine manually.
- 7. Engine Speed Lever** Used to adjust engine speed to control pump output.
- 8. On/Off Switch** Set this switch to "On" before using recoil starter. Set switch to "Off" to stop a running engine.
- 9. Oil Drain** Drain engine oil here.
- 10. Oil Fill** Check and add engine oil here.
- 11. Suction Inlet** Connect reinforced suction hose here.
- 12. Water Drain Plug** Remove to drain water from pump and flush internal components with clean water.
- 13. Pump Chamber** Be sure to fill with water before starting.
- 14. Fuel Shutoff Valve** Used to turn fuel supply on and off to engine.

**Item Not Shown:**

**Strainer Basket** Used to limit passage of abrasive materials into the pump.

Your water pump requires some set up and is ready for use after it has been properly serviced with the recommended oil and fuel.

If you have any problems with the set up of your water pump, please call the pressure washer help line at (02) 4577 2144 and email : sales@bargroup.com.au If calling for assistance, please have the model and serial number from the data tag available.

### Connect Suction Hose to Pump

1. Slide hose clamp (A) over end of hose (B). Slide suction hose onto hose barb (C). Tighten hose clamp securely to the hose.

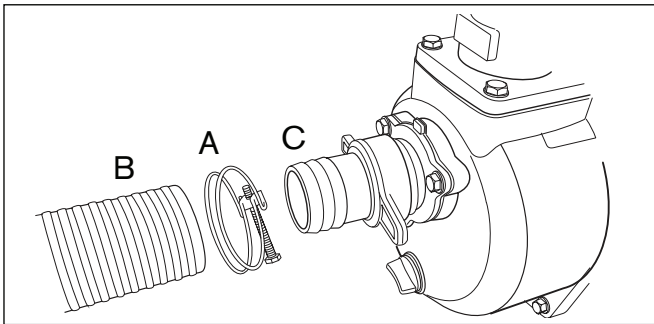

### Attach Suction Hose to Strainer basket

1. Slide hose clamp over hose. Attach open end of suction hose to strainer hose barb. Tighten hose clamp securely.

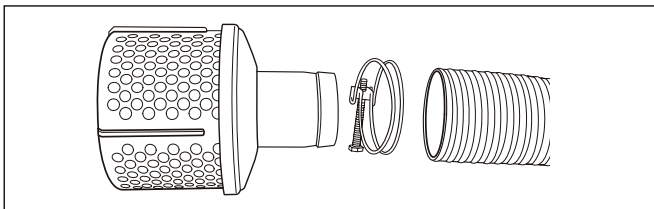

### Connect Discharge Hose (Optional)

If desired, use a commercially available hose. DO NOT use a hose with an inside diameter smaller than the pump's discharge port size.

1. Slide barb cuff over hose barb. Insert rubber seal into end of barb cuff as shown earlier.
2. Screw hose barb assembly onto pump in clockwise rotation until hose barb assembly is tightened securely.

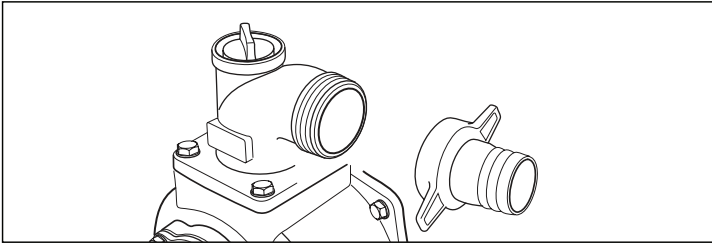

3. Slide hose clamp over end of discharge hose. Slide discharge hose onto hose barb. Tighten hose clamp securely.

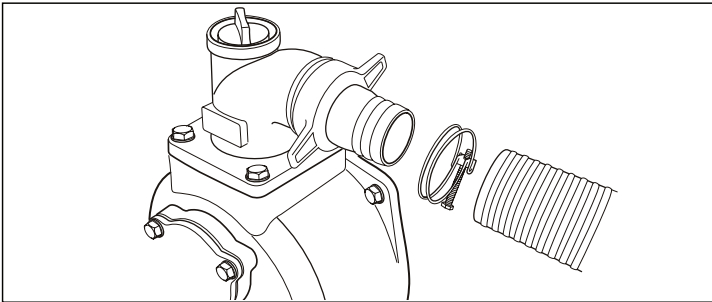

4. You may choose to assemble the discharge and suction hose as shown above or by using camlock connections. Camlocks are another commonly used water pump connection.

# OPERATION

## What is “Head”

Head refers to the height of a column of water that can be delivered by the discharge of the pump.

Suction Head is the vertical distance between the center of the pump and the surface of the liquid on the suction side of the pump. May also be referred to as “suction lift”. The atmospheric pressure of 14.7 psi at sea level limits suction head lift to less than approximately 26 feet for any pump.

Discharge Head is the vertical distance between the pump’s discharge port and the point of discharge, which is the liquid surface if the hose is submerged or pumping into the bottom of a tank.

Total Head is the sum of the suction head value plus the discharge head value.

As water pumping height increases, pump output decreases. The length, type, and size of the suction and discharge hoses can also significantly affect pump output.



It is important for the suction operation to be the shorter part of the total pumping action. This will decrease the priming time and improve pump performance by increasing the discharge head.

Suction head is a maximum of 25 feet and discharge head should be a maximum of 81 feet. Total head can not be more than 106 feet as shown on next page.

## Move Water Pump to Safe Operating Location

For best pump performance, locate the pump on a flat, level surface as close as possible to the water to be pumped. Secure water pump to avoid tipover. Use hoses that are no longer than necessary.

**IMPORTANT:** Direct open end of discharge hose away from home, electrical devices or anything not desired to get wet.

 <b>WARNING</b>	
 	<p>Fuel and its vapors are extremely flammable and explosive.</p> <p>Fire or explosion can cause severe burns or death.</p>
<ul style="list-style-type: none"> <li>▪ This water pump is not for use in mobile equipment or marine applications</li> <li>▪ DO NOT tip engine or equipment at angle which causes fuel to spill.</li> <li>▪ Secure water pump. Loads from hoses may cause tip over.</li> </ul>	

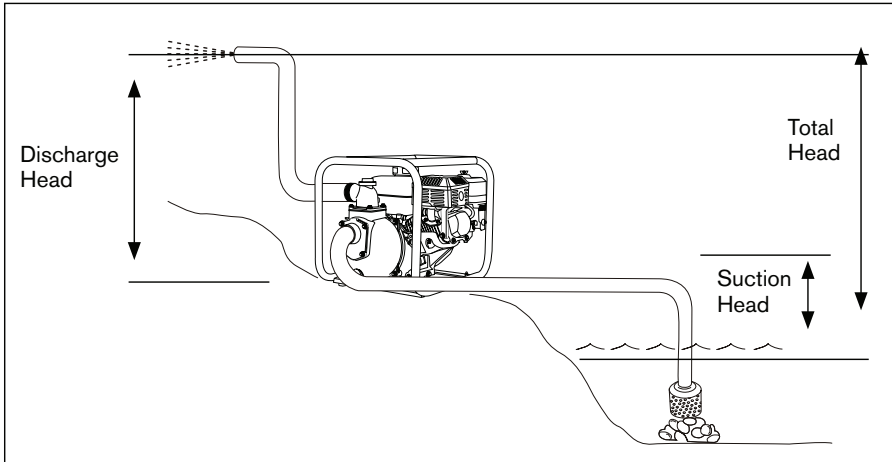

### Prime the Water Pump

1. Remove priming plug from top of pump.
2. Fill pump with clean, clear water up to top of discharge outlet.
3. Replace priming plug.

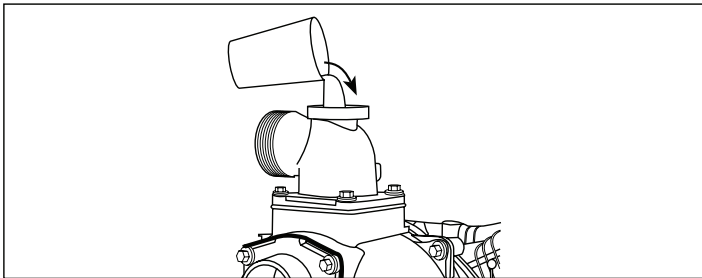

### NOTICE

Improper treatment of water pump can damage it and shorten its life.

- Be sure chamber is filled with water before starting the engine.
- NEVER run pump without priming



## Locate Strainer Basket Into Water Source

Place strainer basket into water to be pumped. Basket must be fully immersed.

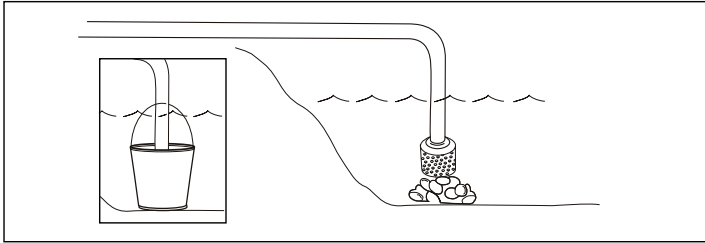

## NOTICE

Improper treatment of water pump can damage it and shorten its life.

- NEVER operate pump without strainer connected to end of suction hose.
- Keep strainer out of sand or silt, place in bucket or on stones.
- DO NOT let pump run dry or damage to seals may result.

**Starting the Water Pump**

Use the following start instructions:

1. Make sure unit is on a flat, level surface and pump chamber is primed.
2. Turn fuel valve (1) to "On" position. The fuel valve handle will be vertical (pointing toward the ground).

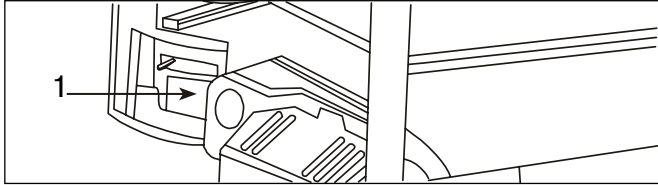

3. Push on/off switch (2) to "On" position.
4. Move engine speed lever (3) to "Fast" ( ) position.

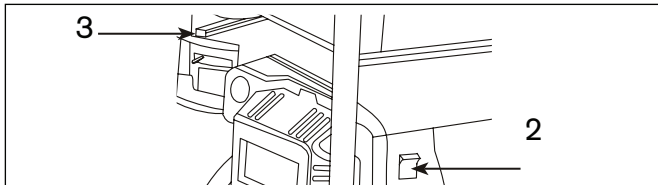

5. Move choke lever (4) to "On" position.

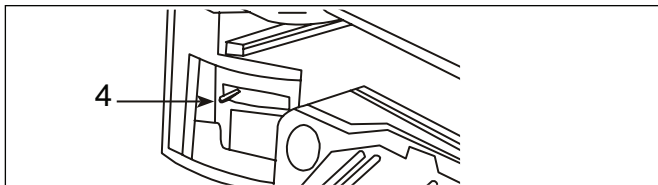

6. Grasp recoil handle and pull slowly until slight resistance is felt. Then pull handle rapidly to overcome compression, prevent kickback and start engine.

**⚠ WARNING**

Starter cord kickback (rapid retraction) can result in bodily injury. Kickback will pull hand and arm toward engine faster than you can let go.

Broken bones, fractures, bruises, or sprains could result.



- When starting engine, pull cord slowly until resistance is felt and then pull rapidly to avoid kickback.

## STARTING THE WATER PUMP

**IMPORTANT:** If excessive fuel is present in the air/fuel mixture causing a “flooded” condition, move choke lever to “Run” position and pull handle repeatedly until engine starts.

7. Move choke lever to “Run” position a short distance at a time over several seconds in warm weather or minutes in cold weather. Let engine run smoothly before each change. Operate with choke in “Run” position.

**IMPORTANT:** It may take a few minutes for water pump to begin pumping water.

 <b>WARNING</b>	
 	<p>Contact with muffler area can result in serious burns.</p> <p>Exhaust heat/gases can ignite combustibles, structures or damage fuel tank causing a fire.</p>
<ul style="list-style-type: none"><li>▪ DO NOT touch hot parts and AVOID hot exhaust gases.</li><li>▪ Allow equipment to cool before touching.</li><li>▪ Keep at least 5 feet (1.5 m) of clearance on all sides of pressure washer including overhead.</li></ul>	

Pump output is controlled by adjusting engine speed. Moving the engine speed lever in the “Fast” direction will increase pump output, and moving the engine speed lever in the “Slow” direction will decrease pump output.

**Stopping the Water Pump**

1. Move engine speed lever to “Slow” position.
2. Push on/off switch to “Off” position.
3. Turn fuel valve to “Off” position.

**⚠ WARNING**

Backfire, fire or engine damage could occur.

- DO NOT stop engine by moving choke control to “Choke” position.

**Drain and Flush Water Pump**

1. Disconnect and drain suction and discharge hoses.
2. Remove drain plug at bottom of pump.

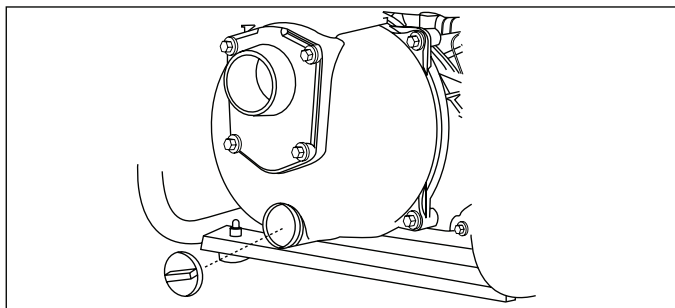

3. Remove primer plug from top of pump and flush internal components of pump with clean water.

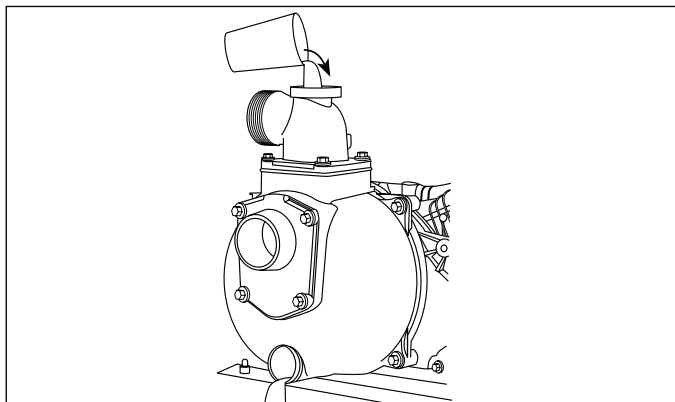

4. Replace both plugs and finger tighten.

# HOW TO CHOOSE A WATER PUMP

Application / Job Type	High Pressure Transfer / Fire Pump	Transfer Pump	Semi Trash	Trash Pump	Poly Pumps
Clean Water	✓	✓			
Slimy Water		✓			
Mucky Water		✓	✓		
Muddy Water			✓	✓	
Silt Water			✓	✓	
Abrasive Water				✓	
High Solid Content Water				✓	
Seepage Ditch Water				✓	
Septic Tanks / Effluent Pump Out				✓	
Man Holes		✓	✓		
Construction Site Dewatering			✓	✓	
Long Distance Transfer, High Head, Fire Fighting	✓				
High Volume Transfer - Shorter Distance, Low Head		✓			
Chemicals / Fertilizer / Pesticides					✓
Salt Water / Brine					✓
Diesel Fuel	✓ w VITON Elastomer Option	✓ w VITON Elastomer Option			✓ w NBR or Viton Elastomer

Use as a guide only, ask your local BAR rep for more advice if needed.  
 Check out our website for Poly Pump chemical compatibility chart QR scan code on page 7  
 Fit suction hose with strainer provided

## Fire Fighting

BE Fire Pumps are the ideal choice for home and property protection plus high pressure transfer.



### Applications

- Fire fighting, mop up and generation fire protection.
- High pressure or long distance water transfer
- Machinery wash down
- Spray irrigation
- Stock crate washdown
- Sheep jetting
- Boom spraying
- High Pressure spraying
- Diesel fuel transfer if fitted with viton seals

## Water Transfer

BE Water Transfer Pumps are designed to move large volumes of water fast over short distances.



### Applications

- High volume water transfer
- Fast filling of water tanks
- Flood irrigation
- Dam filling
- Water carts
- Diesel fuel transfer if fitted with viton seals

## Dirty or Debris Filled Water

BE Semi-Trash and Trash Pumps feature enhancements suitable for handling dirty water while still maintaining a high flow rate.



### Applications

- Construction site dewatering
- Effluent pump out
- Water water or dirty water handling
- Mine waste pump out
- Livestock waste water disposal

## Corrosive Materials Specialists

BE 2" & 3" Poly Pumps are best suited for pumping corrosive or aggressive chemicals. Available with your choice of Viton, EPDM, or NBR elastomer.



### Applications

- Liquid fertilizer
- Pesticides
- Diesel Fuel
- Salt Water
- Marine firefighting & salvage
- Caustic liquids
- High volume transfer
- Liquid stock feed and supplements

## Ultra-Lites

BE Ultralite Pumps are lightweight but sturdy 1" & 1.5" transfer pumps providing portability and flexibility.



### Applications

- Water transfer
- Mop up / fire fighting
- Emergency floods
- Camp sites
- Irrigation
- Spraying
- Diesel fuel transfer if fitted with viton seals

Practically all breakdowns can be prevented by proper handling and maintenance inspections, but in the event of an issue check the Troubleshooting information shown below.

SYMPTOM	POSSIBLE PROBLEM	SOLUTION
Pump does not take on water.	Not enough priming water in the housing?	Add more water
	Engine speed too low?	Increase throttle
	Strainer plugged?	Clean strainer
	Suction hose damaged?	Replace or repair hose & clamps
	Air leak at suction port?	Check that fittings are tight & sealed, ensure hose coupling seal is in good condition.
	Pump is located too high above water line?	Move pump closer to water
	Debris collecting in pump housing?	Clean pump housing
	Too much distance between impeller and volute.	Adjust clearance by adding shims or replace impeller. Min. .010" -Max. .020
	Water leaking out weep hole between pump and engine?	Check condition of mechanical seal & gaskets, between pump end and engine housing
	Suction lift or discharge head too high.	Check hose/pipe installation
Pump takes in water, little or no discharge.	Engine speed too low?	Increase throttle speed
	Suction strainer partially plugged?	Clean strainer
	Impeller/volute worn?	Adjust clearance by adding shims or replace impeller/volute
Suction hose leaks at inlet	<b>Fittings/clamps are not sealed properly?</b>	Tighten, replace or add clamp. (Keep extra seals on pump)
	Hose diameter is too large?	Use smaller diameter hose or replace hose
Discharge hose does not stay on coupling.	Pressure too high?	Check pressure, add additional clamp
	Hose kinked or end blocked?	Check hose
Impeller does not turn, pump is hard to start.	Impeller jammed or blocked?	Open pump cover and clean dirt and debris from inside housing
	Impeller and volute binding?	Adjust clearance by removing shim from behind impeller
	Defective engine?	See Engine Owners Manual

**EMERGENCY USE ONLY ... low oil cut-out on Honda engines can be disabled by disconnecting the yellow wire that leads to the starter. NOTE engine warranty may be affected.**

Engine Troubleshooting; refer to engine manufacturer's manual





IF YOU NEED ASSISTANCE WITH THE ASSEMBLY OR  
OPERATION OF THIS WATER PUMP

**CALL**  
(02) 4577 2144

OR

**EMAIL**  
SALES@BARGROUP.COM.AU