

# BE

---

## INVERTER GENERATOR



*G3500i-R*  
*G3500i-RE*

User Manual

---

**BEPOWEREQUIPMENT**

**.COM**



## TABLE OF CONTENTS

---

### **Safety**

- 4 Introduction
- 5 Safety Warnings
- 6 Safety Information

### **Description**

- 9 Description
- 11 Control Panel

### **Control Function**

- 12 3 in 1 switch knob
- 12 Oil warning light (red)
- 13 Overload indicator light (red)
- 13 AC power indicator (green)
- 14 DC protector
- 14 Engine smart control (ESC)
- 15 Fuel tank cap
- 15 Ground (Earth) terminal

### **Preparation**

- 16 Fuel
- 16 Engine oil
- 17 Pre-operation check

### **Operation**

- 18 Operation
- 19 Starting the engine
- 20 Stopping the engine
- 21 Alternating Current (AC) connection
- 21 Battery Charging
- 23 Application range

### **Maintenance**

- 25 Maintenance
- 27 Spark plug inspection
- 28 Carburetor adjustment
- 28 Engine oil replacement
- 29 Air filter
- 30 Muffler screen
- 31 Fuel tank filter
- 31 Fuel filter

### **Storage**

- 32 Drain the fuel
- 32 Engine

### **Troubleshooting**

- 32 Engine won't start
- 34 Generator won't produce power
- 34 Specifications
- 35 Wiring Diagram



**Attention: Read through the complete manual prior to the initial use of your generator.**

### **Using the Operator's manual**

The operating manual is an important part of your generator. It should be read thoroughly before initial use, and referred to often to make sure adequate safety and service concerns are being addressed.

Reading the owner's manual thoroughly will help avoid any personal injury or damage to your machine. By knowing how best to operate this machine you will be better positioned to show others who may also operate the unit.

This manual contains information for the complete range of BE generators, and was written to take you from the safety requirements to the operating functions of your machine. You can refer back to the manual at any time to help troubleshoot any specific operating functions, so store it with the machine at all times.



## Save these Instructions Safety Warnings



This is the safety alert symbol. It is used to alert you to potential personal injury hazards. Obey all safety messages that follow this symbol to avoid possible injury or death.

The safety alert symbol (  ) is used with a signal word (DANGER, CAUTION, WARNING), a pictorial and/or a safety message to alert you to hazards.

**DANGER** you WILL be KILLED or SERIOUSLY HURT if you don't follow instructions.

**WARNING** you CAN be KILLED or SERIOUSLY HURT if you don't follow instructions.

**CAUTION** you CAN be HURT if you don't follow instructions

**NOTICE** your generator or other property could be damaged if you don't follow instructions.

## Hazard Symbols and Meanings



EXPLOSION



FIRE



ELECTRIC SHOCK



TOXIC FUMES





KICKBACK





READ MANUAL

**1. SAFETY INFORMATION**

Read and understand this owner's manual before operating your generator. It will help you avoid accidents if you are familiar with your generator's safe operation procedures.

 <b>WARNING</b>	
	<p>Generator exhaust contains carbon monoxide, a poisonous gas that can kill you.</p> <p>You <b>CANNOT</b> smell or see this gas.</p>
<ul style="list-style-type: none"><li>▪ Use the generator outdoors, away from open windows, vents, or doors that could allow the carbon monoxide gas to come indoors. Keep the generator at least 1 meter (3 feet) away from any structure or building during use.</li><li>▪ <b>NEVER</b> use a generator indoors, including in homes, garages, basements, crawl spaces, and other enclosed or partially-enclosed areas, even with ventilation. Opening doors and windows or using fans will not prevent carbon monoxide build-up in the home.</li><li>▪ <b>NEVER</b> use a generator in enclosed or partially-enclosed spaces. Generators can produce high levels of carbon monoxide very quickly. When you use a portable generator, remember that you cannot smell or see carbon monoxide. Even if you can't smell exhaust fumes, you may still be exposed to carbon monoxide.</li><li>▪ <b>NEVER</b> operate the generator in an explosive atmosphere, near combustible materials or where ventilation is not sufficient to carry away exhaust fumes. Exhaust fumes can cause serious injury or death.</li><li>▪ If you start to feel sick, dizzy, or weak while using a generator, get to fresh air <b>RIGHT AWAY. DO NOT DELAY.</b> The carbon monoxide from generators can rapidly lead to full incapacitation and death.</li><li>▪ If you experience serious symptoms, seek medical attention immediately. Inform medical staff that carbon monoxide poisoning is suspected. If you experienced symptoms while indoors, have someone call the fire department to determine when it is safe to re-enter the building.</li></ul>	

 <b>WARNING</b>	
	Fuel and its vapors are extremely flammable and explosive.
	Fire or explosion can cause severe burns or death.
<b>When Adding or Draining Fuel</b> <ul style="list-style-type: none"><li>▪ Observe all safety regulations for the safe handling of fuel. Handle fuel in safety containers. If the container does not have a spout, use a funnel.</li><li>▪ Do not overfill the fuel tank, leave room for the fuel to expand.</li><li>▪ Do not refill fuel tank while the engine is running. Before refueling the generator, turn it off and let it cool down. Gasoline spilled on hot engine parts could ignite.</li><li>▪ Fill the tank only on an area of bare ground. While fueling the tank, keep heat, sparks and open flame away. Carefully clean up any spilled fuel before starting engine.</li><li>▪ Always fill fuel tank in an area with plenty of ventilation to avoid inhaling dangerous fumes.</li><li>▪ NEVER store fuel for your generator in the home. Gasoline, propane, kerosene, and other flammable liquids should be stored outside of living areas in properly-labeled, non-glass safety containers. Do not store them near a fuel-burning appliance, such as a natural gas water heater in a garage. If the fuel is spilled or the container is not sealed properly, invisible vapors from the fuel can travel along the ground and can be ignited by the appliance's pilot light or by arcing from electric switches in the appliance.</li></ul>	

**WARNING:** This product can expose you to chemicals including lead, which is known to the State of California to cause cancer and birth defects or other reproductive harm. For more information, go to [www.P65Warnings.ca.gov](http://www.P65Warnings.ca.gov). Wash hands after handling.

If the generator should malfunction, grounding provides a path of least resistance for electric current to reduce the risk of electric shock.

 <b>DANGER</b>	
	<p>Improper grounding can result in risk of electrocution. Check with a qualified electrician for your local requirements if you are in doubt as to whether the unit is properly grounded.</p>
<ul style="list-style-type: none"> <li>▪ This generator is equipped with a grounding terminal for added protection. Using the ground path from the generator to an external ground source as instructed in the section labeled “Grounding Instructions” in the Preparation section of this manual can be necessary. Please consult a qualified electrician for local regulations.</li> <li>▪ The generator is a potential source of electrical shock if not kept dry. Keep the generator dry and do not use in rain or wet conditions. To protect from moisture, operate it on a dry surface under an open, canopy-like structure. Dry your hands if wet before touching the generator.</li> <li>▪ Plug appliances directly into the generator. Or, use a heavy duty, outdoor-rated extension cord that is rated (in watts or amps) at least equal to the sum of the connected appliance loads. Check that the entire cord is free of cuts or tears and that the plug has all three prongs, especially a grounding pin.</li> <li>▪ NEVER try to power the house wiring by plugging the generator into a wall outlet, a practice known as “back feeding”. This is an extremely dangerous practice that presents an electrocution risk to utility workers and neighbors served by the same utility transformer. It also bypasses some of the built-in household circuit protection devices.</li> <li>▪ If you must connect the generator to the house wiring to power appliances, have a qualified electrician install the appropriate equipment in accordance with local electrical codes.</li> </ul>	

### 3. DESCRIPTION

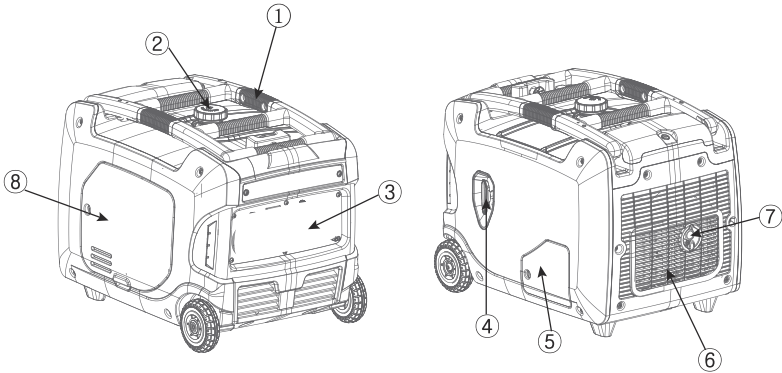

- ① Carrying handle
- ② Fuel tank cap
- ③ Control panel
- ④ Recoil starter
- ⑤ Oil filler cap
- ⑥ Louver
- ⑦ Muffler
- ⑧ Spark plug maintenance cover

#### 3.1 LED Function Display (G3500i-RE)

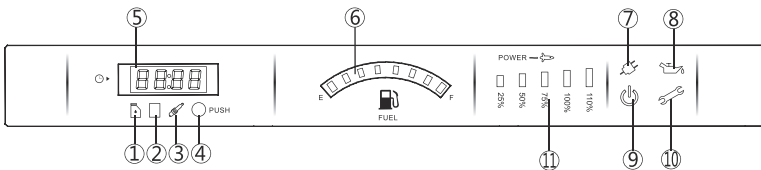

- ① Oil change indicator
- ② Air cleaner maintenance indicator
- ③ Spark plug maintenance indicator
- ④ Switch button
- ⑤ Multi functional digital meter
- ⑥ Fuel level indicator
- ⑦ On-load indicator
- ⑧ Oil alert indicator
- ⑨ Inverter running indicator
- ⑩ Inverter alert indicator
- ⑪ Power display

240V

⑤ — Multi functional digital meter

Voltage-U000, Frequency-F00.0, Total working time-000.0(0.1h) , Working hours at one time-00.00 Switch the display by pushing ④ .

① — Red

Oil change indicator, first time indicate after 50hrs, and then indicate once every 100hrs. Every indicating lasts 1hr.

② — Red

Air cleaner maintenance indicator, indicate once every 100hrs. Every indicating lasts 1hr.

③ — Red

Spark plug maintenance indicator,indicate once every 100hrs. Every indicating lasts 1hr.

⑥ — Fuel level indicator

Full-Green, all lights on Low fuel level-lights turn orange

⑪ — Power display

Power lower than 25%(750W), light A truns green.

Power lower than 50%(1500W), light A&B truns green.

Power lower than 75%(2250W), light A&B&C truns green.

Power lower than 100%(3000W), light A&B&C&D truns green.

Power higher than 100%,but lower than 110%(3000W-3300W), light A&B&C&D truns green&red.

Power higher than 110%(3300W), light A&B&C&D&E trunsred.

⑦ — Green On-load indicator light on green while the inverter is on-load.

⑧ — Red Oil alert light on while the oil is empty

⑨ — Green Inverter working indicator.

⑩ — Red Inverter alert indicator. Light ⑨ is off while this light is constantly on

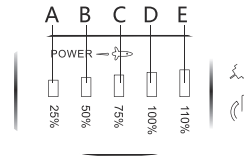

Power display

## DESCRIPTION

### 3.2 Control Panel

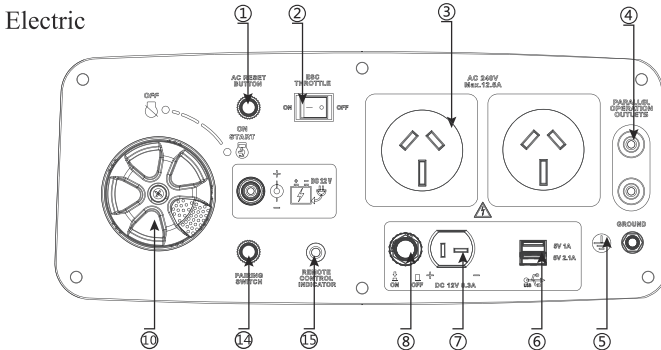
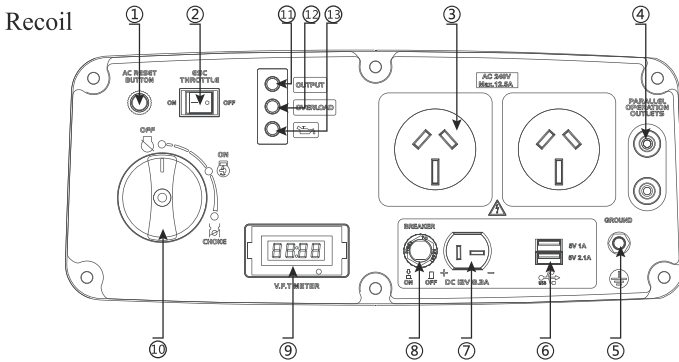



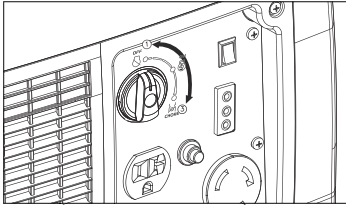

- |                             |                            |
|-----------------------------|----------------------------|
| ① AC reset                  | ⑥ USB                      |
| ② ESC(Engine Smart Control) | ⑦ DC receptacle            |
| ③ AC receptacle             | ⑧ DC protector             |
| ④ Parallel function         | ⑨ V.F.T                    |
| ⑤ Ground (earth) terminal   | ⑩ Switch knob              |
| ⑪ AC pilot light            | ⑫ Overload indicator light |
| ⑬ Oil warning light         | ⑭ Pairing switch           |
| ⑮ Remote control indicator  |                            |

### 4. CONTROL FUNCTION

#### 4.1 3 in 1 switch knob



- (1) Engine switch\fuel valve  "OFF";  
Ignition circuit is switched off. Fuel is switched off.  
The engine will not run.
- (2) Engine switch\fuel valve  "ON";  
Ignition circuit is switched on. Fuel is switched on. Choke is switched off. The engine can be running after initial starting.
- (3) Engine switch\fuel valve\choke  "CHOKE";  
Ignition circuit is switched on. Fuel is switched on. Choke is switched on. The engine can be started.

**TIP:** The choke  is not required to start a warm engine.

#### 4.2 Oil warning light (red)

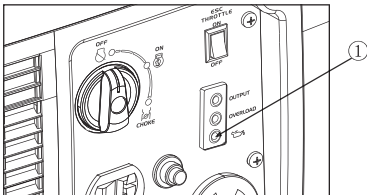

When the oil level falls below the lower level, the oil warning light (1) comes on and then the engine stops automatically. Unless you refill with oil, the engine will not start again.

**TIP:** If the engine stalls or does not start, turn the engine switch to "ON" and then pull the recoil starter. If the oil warning light flickers for a few seconds, the engine oil is insufficient. Add oil and restart.



### 4.3 Overload indicator light (red)

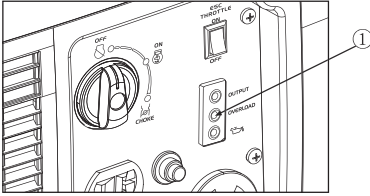

The overload indicator light (1) comes on when an overload of a connected electrical device is detected, the inverter control unit overheats, or the AC output voltage rises. Then, the AC protector will trip, stopping power generation in order to protect the generator and any connected electric devices. The AC pilot light (Green) will go off and the overload indicator light (Red) will stay on, but the engine will not stop running.

When the overload indicator light comes on and power generation stops, proceed as follows:

1. Turn off any connected electric devices and stop the engine.
2. Reduce the total wattage of connected electric devices within the rated output.
3. Check for blockages in the cooling air inlet and around the control unit. If any blockages are found, remove.
4. After checking, restart the engine.

**TIP:** The overload indicator light may come on for a few seconds at first when using electric devices that require a large starting current, such as a compressor or a submersible pump. However, this is not a malfunction.

### 4.4 AC power indicator (green)

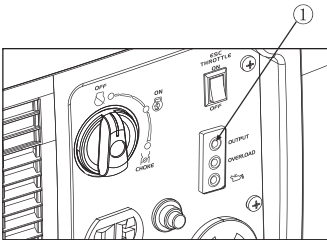

The AC power indicator (1) comes on when the engine starts and produces power.

### 4.5 DC protector

The DC protector turns to “OFF” (2) automatically when electric device being connected to the generator is operating and current above the rated flows. To use this equipment again, turn on DC protector by pressing its button to “ON” (1)

- (1) “ON”  
Direct current is output.
- (2) “OFF”  
Direct current is not output.

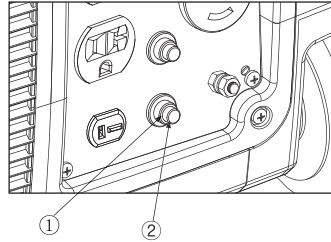

### ⚠ CAUTION

- Reduce the load of the connected electric device below the specified rated output of the generator if the DC protector turns off. If the DC protector turns off again, stop using the device immediately and consult our company authorized dealer.

### 4.6 Engine smart control (ESC)

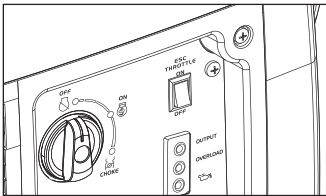

- (1) “ON”

When the ESC switch is turned to “ON”, the economy control unit controls the engine speed according to the connected load. The results are better fuel consumption and less noise.

- (2) “OFF”

When the ESC switch is turned to “OFF”, the engine runs at the rated r/min(4500r/min) regard-less of whether is a load connected or not.

**TIP:** The ESC must be turned to “OFF” when using electric devices that require a large starting current, such as a compressor of a submergible pump.

### 4.7 Fuel tank cap



Remove the fuel tank cap by turning it counterclockwise.

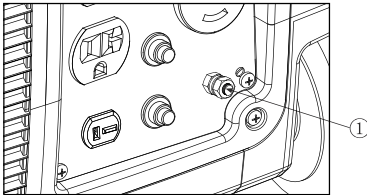

### 4.8 Ground (Earth) terminal



Ground (Earth) terminal (1) connects the earth line for prevention of electric shock. All electrical tools and appliances operated from this generator, must be properly grounded by use of a third wire or be "Double Insulated"

### 5. PREPARATION

#### 5.1 Fuel

 <b>DANGER</b>	
	<ul style="list-style-type: none"><li>▪ Fuel is highly flammable and poisonous. Check “SAFETY INFORMATION” carefully before filling.</li><li>▪ Do not overfill the fuel tank, otherwise it may overflow when the fuel warms up and expands.</li><li>▪ After filling, make sure the fuel tank cap is tightened securely.</li></ul>

<b>NOTICE</b>
<ul style="list-style-type: none"><li>▪ Immediately wipe off spilled fuel with a clean, dry, soft cloth, since fuel may deteriorate painted surfaces or plastic parts.</li><li>▪ Use only unleaded gasoline. The use of leaded gasoline will cause severe damage to internal engine parts.</li></ul>

Remove the fuel tank cap and fill the fuel into the tank up to the red level.

(1) Red line

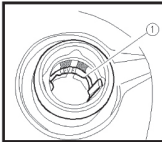

(2) Fuel level

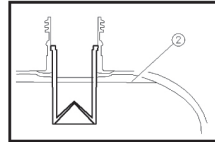

Recommended fuel: Unleaded gasoline Fuel tank capacity: Total: 9.5L (2.51 US gal, 2.09 Imp gal)
--

#### 5.2 Engine oil

<b>NOTICE</b>
<ul style="list-style-type: none"><li>▪ Check oil levels before starting the engine. If empty, refill with sufficient engine oil.</li></ul>

1. Place the generator on a level surface.
2. Turn the oil service knob to “OPEN” and remove the service door.

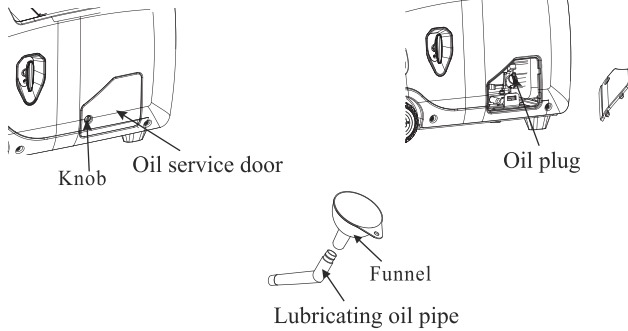

3. Unscrew the oil plug and then screw the sealing screw into the pouring orifice. Use the funnel to aid the specified amount of oil.
4. Screw the oil plug back in, reinstall the oil service door, and turn the knob to the "CLOSED" position.

Recommended engine oil: SAE SJ 15W-40  
 Recommended engine oil grade: API Service SE type or higher  
 Engine oil quantity: 0.55L

### 5.3 Pre-Operation check

**⚠ WARNING**

- If any item in the Pre-operation check is not working properly, have it inspected and repaired before operating the generator.
- The condition of a generator is the owner's responsibility. Vital components can start to deteriorate quickly and unexpectedly, even if the generator unused.

**TIP:** Pre-operation checks should be made each time the generator is used.

#### Pre-operation check

##### Fuel (See page 16)

- Check fuel level in fuel tank.
- Refuel if necessary.

##### Engine oil (See page 17)

- Check oil level in engine.
- If necessary, add recommended oil to specified level.
- Check generator for oil leakage.

**6. OPERATION** **WARNING**

- Never operate the engine in a closed area or it may cause unconsciousness and death within a short time. Operate the engine in a well ventilated area.
- Before starting the engine, do not connect any electric devices.

**NOTICE**

- The generator has been shipped without engine oil. Do not start the engine till fill with the sufficient engine oil.
- Do not tilt the generator when adding engine oil. This could result in overfilling and damage to the engine.

**TIP:** The generator can be used with the rated output load at standard atmospheric conditions.

“Standard atmospheric conditions”

Ambient temperature 25°

Barometric pressure 100kPa

Relative humidity 30%

The output of the generator varies due to change temperature, altitude (lower air pressure at higher altitude) and humidity.

The output of the generator is reduced when the temperature, the humidity and the altitude are higher than standard atmospheric conditions.

Additionally, the load must be reduced when using in a confined area, as generator cooling is affected.

### 6.1 Starting the engine

1. Turn the ESC switch to “OFF” (1).

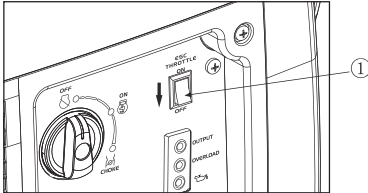

2. Turn the air vent knob to “ON” (2).

3. Turn the 3 in 1 switch to  CHOKE” (3),
  - a. Ignition circuit is switched on.
  - b. Fuel is switched on.
  - c. Choke is switched on

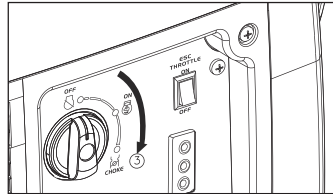

**TIP:** The choke is not required to start a warm engine. Push the choke knob in to the position  “ON”.

4. Pull slowly on the recoil starter until it is engaged, then pull it briskly.

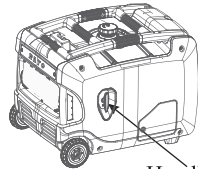

Handle

**TIP:** Grasp the carrying handle firmly to prevent the generator from falling over when pulling the recoil starter.

5. After the engine starts, warm up the engine until the engine does not stop when the choke knob is returned to the  “ON” position (4).

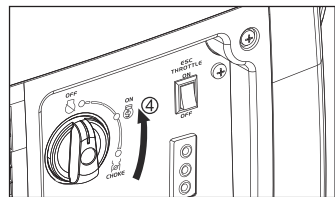

**TIP:** When starting the engine, with the ESC “ON”, and there is no load on the generator:

- In ambient temperature below 0°C (32°F), the engine will run at the rated r/min (4500r/min) for 5 minutes to warm up the engine.
- In ambient temperature below 5°C (41°F), the engine will run at the rated r/min (4500r/min) for 3 minutes to warm up the engine.
- The ESC unit operates normally after the above time period, while the ESC is “ON”.

### Operating instructions for Remote control electric start:

- a: Turn the engine switch knob to the “ON / START” position;
- b: Press the “ON” button on the remote control, and release it when the LED of the remote control is on, and the controller will start the engine automatically. Repeat the operation if failed to start for the first time.

**\*The maximum distance for remote start is 80m.**

### The remote control pairing:

Due to damage of the remote control or other reasons, the remote control and the engine need to be re-paired according to the instructions below.

- 1) When the engine is off, turn the switch knob to the “ON” position (the engine can not be started) to turn on the controller.
- 2) Press and hold the pairing switch on the generator control panel, do not release it until the pairing indicator light is on
- 3) Tap any button on the new remote control, when the pairing indicator on the panel flashes 3 times and then goes out, it indicates that the pairing is successful. (Note: 1. The pairing needs to be finished within 5 seconds after the pairing function is turned on, or the controller will automatically exit the pairing mode; 2. One generator can only be paired with one remote control, the original one will become invalid after the new pairing is successful)

### 6.2 Stopping the engine

**TIP:** Turn off any electric devices.

- 1. Turn the ESC to “OFF” (1).

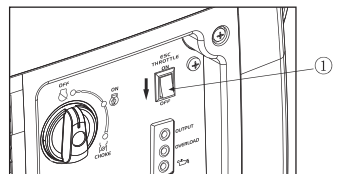

- 2. Disconnect any electric devices.

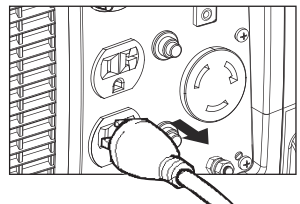



3. Turn the 3 in 1 switch to  "OFF" (2),
  - a. Ignition circuit is switched off.
  - b. Fuel is switched off.

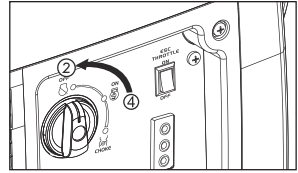

**CAUTION:** If the engine is not used for a long time, be sure to turn the switch knob to the "OFF" position and disconnect the red lead from the battery in order to shut off the power and fuel to the circuit, or it could cause the battery to lose power and fail to start.

Method 1: Set the engine switch knob directly to the "OFF" position

Method 2: Press the "OFF" button on the remote control, and release it when the LED of the remote control is on, the controller will automatically shut down the engine.

### 6.3 Alternating Current (AC) connection

#### WARNING

- Be sure any electric devices are turned off before plugging them in.

#### NOTICE

- Be sure all electric devices including the lines and plug connections are in good condition before connection to the generator.
- Be sure the total load is within generator rated output.
- Be sure the receptacle load current is within receptacle rated current.
- The generator (STATOR WINDING) is isolated from the AC receptacle ground pin.
- Electrical devices that require a grounded receptacle pin connection will not function if the receptacle ground pin is not functional.

**TIP:** Make sure to ground the generator. When the electrical device is grounded, the generator must also be grounded.

1. Start the engine.
2. Turn the ESC to "ON".
3. Plug in to AC receptacle.
4. Make sure the AC pilot light is on.
5. Turn on any electric devices.

**TIP:** The ESC must be turned to “OFF” to increase engine speed to rated rpm. If the generator is connected to multiple loads or electricity consumers, please remember to first connect the one with the highest starting current and last connect the one with the lowest starting current.

## **6.4 Battery Charging**

**TIP:**

- The generator DC rated voltage is 12V.
  - Start the engine first, and then connect the generator to the battery for charging.
  - Before starting to charge the battery, make sure that the DC protector is turned on.
1. Start the engine.
  2. Connect the red battery charger lead to the positive (+) battery terminal.
  3. Connect the black battery charger lead to the negative (-) battery terminal.
  4. Turn the ESC “off” to start battery charging.

### **NOTICE**

- Be sure the ESC is turned off while charging the battery.
- Be sure to connect the red battery charger lead to the positive (+) battery terminal, and connect the black lead to the negative (-) battery terminal. Do not reverse these positions.
- Connect the battery charger leads to the battery terminals securely so that they are not disconnected due to engine vibration or other disturbances.
- Charge the battery in the correct procedure by following instructions in the owner’s manual for the battery.
- The DC protector turns off automatically if current above the rated flows during battery charging. To restart charging the battery, turn the DC protector on by pressing its button to “ON”. If the DC protector turns off again, stop charge the battery immediately and consult our company authorized dealer.

**TIP:**





- Follow instructions in the owner’s manual for the battery to determine the end of battery charging.

- Measure the specific gravity of electrolyte to determine if the battery is fully charged. At full charge, the electrolyte specific gravity is between 1.26 and 1.28.
- It is advisable to check the specific gravity of the electrolyte at least once every hour to prevent overcharging the battery.

<b>WARNING</b>	
<ul style="list-style-type: none"> <li>▪ Never smoke or make and break connections at the battery while charging. Sparks may ignite the battery gas.</li> <li>▪ Battery electrolyte is poisonous and dangerous, causing severe burns, etc. contains sulfuric (sulphuric) acid. Avoid contact with skin, eyes or clothing.</li> <li>▪ Antidote:  <b>EXTERNAL:</b> Flush with water.  <b>INTERNAL:</b> Drink large quantities of water or milk. Follow with milk of magnesia, beaten egg or vegetable oil . Call physician immediately.  <b>EYES:</b> Flush with water for 15 minutes and get prompt medical attention.</li> <li>▪ Batteries produce explosive gases. Keep sparks, flame, cigarettes, etc., away. Ventilate when charging or using in closed space. Always cover eyes when working near batteries.</li> <li>▪ Keep out of reach of children.</li> </ul>	

### 6.5 Application range

When using the generator, make sure the total load is within rated output of a generator. Otherwise, generator damage may occur.

AC				DC 
Power Factor	1	0.8-0.95	0.4-0.75 (Efficiency 0.85)	
Rated output power	≤3,000W	≤2,400W	≤1,020W	Rated voltage 12V

**TIP:**

- Application wattage indicates when each device is used by itself.
- The simultaneous usage of AC and DC power is possible but total wattage should not exceed the rated output.

**EX:**

Generator rated output		3,000W
Frequency	Power factor	
AC	1.0	≤3,000W
DC	---	100W (12V/8.3A)

The overload indicator (1) comes on when total wattage exceeds the application range. (See page 11 for more details.)

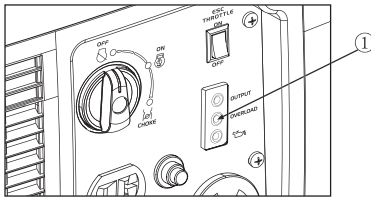
**NOTICE**

- Do not overload. The total load of all electrical appliances must not exceed the supply range of the generator. Overloading will damage the generator.
- When supplying precision equipment, electronic controllers, PCs, Electronic computers, microcomputer based equipment or battery chargers, keep the generator a sufficient distance away to prevent electrical interference from the engine. Also ensure that electrical noise from the engine does not interfere with any other electrical devices located near the generator.
- If the generator is to supply medical equipment, advice should first be obtained from the manufacturer, a medical professional or hospital.
- Some electrical appliances or general-purpose electric motors have High starting currents, and cannot therefore be used, even if they lie within the supply ranges given in the above table. Consult the equipment manufacturer for further advice.

## 7. MAINTENANCE

The engine must be properly maintained to ensure its operation is safe, economical and trouble-free, as well as eco-friendly.

In order to keep your gasoline engine in good working condition, it must be periodically serviced. The following maintenance schedule and routine inspection procedures must be carefully followed:

Items	Frequency	Each time	First 1 month or first 20hrs of operation	Thereafter, every 3 months or every 50hrs of operation	Every year or every 100hrs of operation
Engine oil	Check-Refill	X			
	Replace		X	X	
Reduction gear oil (if equipped)	Oil level check	X			
	Replace		X	X	
Air filter element	Check	X			
	Clean		X		
	Replace			X	
Deposit Cup (if equipped)	Clean				X
Spark Plug	Check-adjust				X
	Replace	Every year or 250hrs of operation			
Spark arrester	Clean			X	
Idling (if equipped)*	Check-adjust				X
Valve clearance*	Check-adjust				X
Fuel tank & fuel filter*	Clean				X
Fuel line	Check	Every 2 years (change if necessary)			
Cylinder head, piston	Clean up carbon*	<225cc, Every 125hrs ≥ 225cc, Every 250hrs			
* These items should be maintained and repaired by our authorized dealer, unless the owner has appropriate tools and is proficient with mechanical maintenance.					

**NOTICE**

- If the gasoline engine frequently works under high temperature or heavy load, change the oil every 25 hours.
- If the engine frequently work under dusty or other severe circumstances, clean the air filter element every 10 hours; If necessary, change the air filter element every 25 hours.
- The maintenance period and the exact time (hour), the one which comes first should govern.
- If you have missed the scheduled time to maintain your engine, do it as soon as possible.

 **WARNING**

- Stop the engine before servicing. Put the engine on a level surface and remove the spark plug cap to prevent the engine from starting.
- Do not operate the engine in a poorly ventilated room or other enclosed area. Be sure to keep good ventilation in working area. The exhaust from the engine may contain poisonous CO, inhalation can cause shock, unconsciousness and even death.

## 7.1 Spark plug inspection

The spark plug is an important engine component which should be checked periodically.

1. Remove the cover (1) and the spark plug cap (2). Insert the tool through the hole from the outside of the cover.

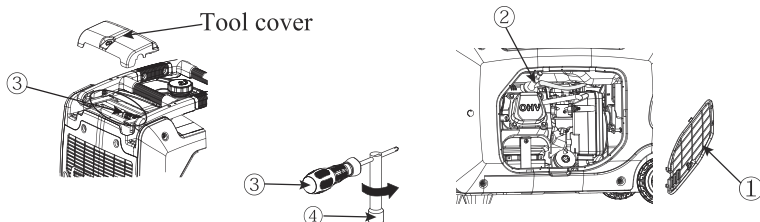

2. Insert the handlebar (3) into the tool (4) and turn it counterclockwise to remove the spark plug.
3. Check for discoloration and remove the carbon. The porcelain insulator around the center electrode of spark plug should be a medium-to-light tan color.
4. Check the spark plug type and gap.

R210 Spark Plug:  
TORCH F6RTC/F6TC  
Spark Plug Gap: 0.6-0.8mm(0.024-0.03in)

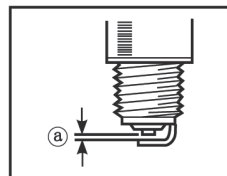

**TIP:** The spark plug gap should be measured with a wire thickness gauge and, if necessary, adjusted to specification.

5. Install the spark plug.

Spark Plug Torque: 28 N\*m (1.25 kgf\*m, 9 lbf\*ft)

**TIP:** If a torque wrench is not available when installing a spark plug, a good estimate of the correct torque is 1/4-1/2 turn past finger tight. However, the spark plug should be tightened to the specified torque as soon as possible.

6. Reinstall the spark plug cap and spark plug cover.

## 7.2 Carburetor adjustment

The carburetor is a vital part of the engine. Adjusting should be left to our company authorized dealer with the professional knowledge, specialized date, and equipment to do so properly.

## 7.3 Engine oil replacement

### **WARNING**

- Avoid draining the engine oil immediately after stopping the engine. The oil is hot and should be handled with care to avoid burns.

Avoid draining the engine oil immediately after stopping the engine. The oil is hot and should be handled with care to avoid burns.

1. Place the generator on a level surface and warm up the engine for several minutes. Stop the engine by turning the switch to "OFF".
2. Remove the screws and then remove the cover.
3. Remove the oil filler cap .
4. Place an oil pan under the engine. Tilt the generator to drain the oil completely.
5. Place the generator on a level surface once more.
6. Add engine oil to the upper level.
7. Wipe the cover clean, and wipe up any spilled oil.
8. Install the oil filler cap.
9. Install the cover and tighten the screws.

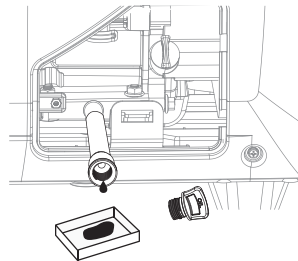
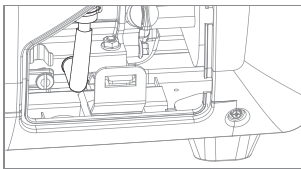

Recommended engine oil: SAE SJ 15W-40  
Recommended engine oil grade: API Service SE type or higher  
Engine oil quantity: 0.55L



## NOTICE

- Do not tilt the generator when adding engine oil. This could result in overfilling and damage to the engine.

## NOTICE

- Be sure no foreign material enters the crankcase.

### 7.4 Air filter

1. Remove the screws (1), and then remove the cover (2).
2. Remove the screw (3) and then remove the air filter case cover (4).

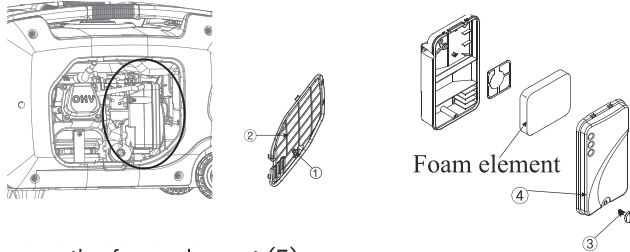

3. Remove the foam element (5).
4. Wash the foam element in solvent and dry it.
5. Oil the foam element and squeeze out excess oil.  
The foam element should be wet but not dripping.

Foam element



## NOTICE

- Do not wring out the foam element when squeezing it. This could cause it to tear.

6. Insert the foam element into the air filter case.

**TIP:** Be sure the foam element sealing surface matches the air filter so there is no air leak.

**The engine should never run without the foam element; excessive piston and cylinder wear may result.**

7. Install the air filter case cover in its original position and tighten the screw.
8. Install the cover and tighten the screws.

### **7.5 Muffler Screen and Spark Arrestor**

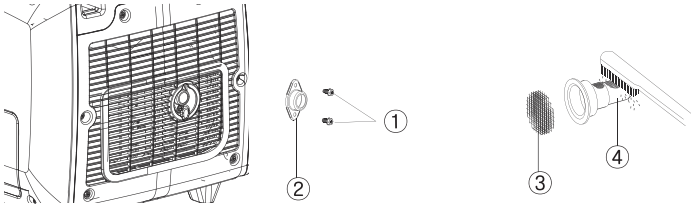

1. Remove the screws (1).
2. Remove the muffler cap (2), the muffler screen (3) and the spark arrester (4).
3. Clean the carbon deposits on the silencer screen and the spark arrester with a wire brush.
4. Check the muffler screen and the spark arrester. Replace if damaged.
5. Reinstall the spark arrester.

## 7.6 Fuel tank filter

**⚠ WARNING**

- Never use the gasoline while smoking or in the vicinity of an open flame.

1. Remove the fuel tank cap and filter.
2. Clean the filter.
3. Wipe the filter dry and reinstall it.
4. Install the fuel tank cap.

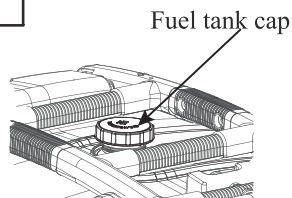

**Be sure the fuel tank cap is tightened securely.**

## 7.7 Fuel filter

1. Remove the screws (1), and then remove the cover (2), and drain the fuel.

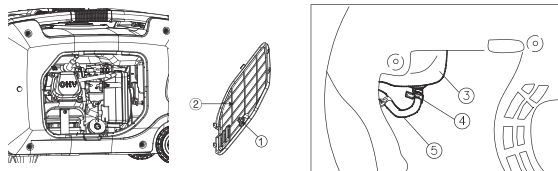

2. Hold and move up the clamp (4), then take off the hose (5) from the tank.
3. Take out the fuel filter.
4. Clean the filter.
5. Dry the filter and put it back into tank.
6. Install the hose and clamp, then open the fuel valve to check for leaks.
7. Install the cover and tighten the screws.

## 8. STORAGE

Long term storage of your machine will require some preventive procedures to guard against deterioration.

### 8.1 Drain the fuel

1. Turn the 3 in 1 switch to "OFF" (1).

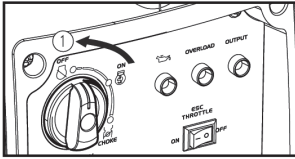

2. Remove the fuel tank cap, remove the filter . Extract the fuel from the fuel tank into an approved gasoline container. Then, install the fuel tank cap.

#### **WARNING**

- Fuel is highly flammable and poisonous. Check "SAFETY INFORMATION" (See page 6) carefully.

#### **NOTICE**

- Immediately wipe off spilled fuel with a clean, dry, soft cloth, since fuel may deteriorate painted surfaces or plastic parts.

3. Start the engine (See Page 19) and leave it running until it stops. The engine stops in approx. 20 minutes. Time by running out of fuel.

**TIP:** Do not connect with any electrical devices. (unloaded operation)  
Duration of the running engine depends on the amount of the fuel left in the tank.

4. Remove the screws, and then remove the cover.
5. Drain the fuel from the carburetor by loosening the drain screw on the carburetor float chamber.
6. Turn the 3 in 1 switch to "OFF".
7. Tighten the drain screw.
8. Install the cover and tighten the screws.

## 8.2 Engine

Perform the following steps to protect the cylinder, piston ring, etc. from corrosion.

1. Remove the spark plug, pour about one tablespoon of SAE 10W-30 into the spark plug hole and reinstall the spark plug. Recoil start the engine by turning over several times (with 3 in 1 switch knob off) to coat the cylinder walls with oil.
2. Pull the recoil starter until you feel compression. Then stop pulling. (This prevents the cylinder and valves from rusting).
3. Clean exterior of the generator. Store the generator in a dry, well-ventilated place, with the cover placed over it.

## 9. TROUBLESHOOTING

### 9.1 Engine won't start

#### 1. Fuel systems

No fuel supplied to combustion chamber.

- No fuel in tank...Supply fuel.
- Fuel in tank....Fuel tank cap and fuel knob to "ON"
- Clogged fuel filter .... Clean fuel filter.
- Clogged carburetor.... Clean carburetor.

#### 2. Engine oil system Insufficient

- Oil level is low.... Add engine oil.

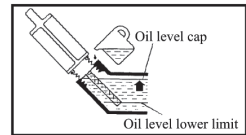

#### 3. Electrical systems

- Put the 1 in 3 switch to "CHOKE" and pull the recoil starter ... Poor spark.
- Spark plug dirty with carbon or wet ... Remove carbon or wipe spark plug dry.
- Faulty ignition system ... consult our company authorized dealer.

## 9.2 Generator won't produce power

- Safety device (DC protector) to "OFF".... Press the DC protector to "ON".
- The AC pilot light (Green) goes off .... Stop the engine, then restart.

## 10. SPECIFICATIONS

Model No.		G3500i-R	G3500i-RE
Generator	Type	Silent Inverter	
	Rated frequency (Hz)	50	
	Rated voltage (V)	240	
	Rated output power (kW)	3.0	3.0
	Power factor	1	
	AC output quality	ISO8528 G2	
	Charging Voltage (DC) (V)	12	
	Charging Current (DC) (A)	8.3	
	Overload Protect (DC)	Non-fuse Protector	
Engine	Engine	R210-i	
	Engine type	Single cylinder, 4-Stroke, forced air cooling, OHV	
	Displacement (cc)	212	
	Fuel type	Unleaded Gasoline	
	Fuel tank capacity (L)	9.5	
	Oil Capacity (L)	0.55	
	Spark Model No.	F6RTC	
Starting mode	Recoil	Electric	
Generator set	Length×Width×Height (mm)	643×480×498	
	Net weight (kg)	42	46

## 11. WIRING DIAGRAM

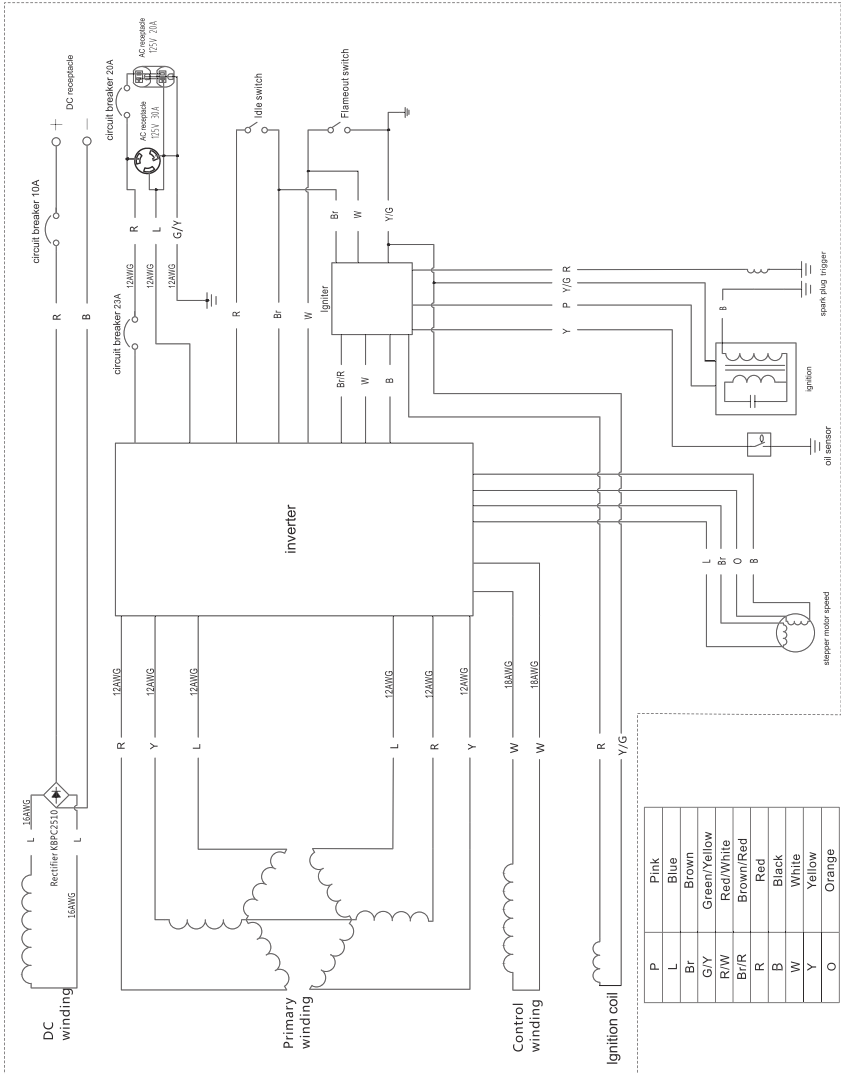

### 12. PARALLEL FUNCTION INSTRUCTIONS

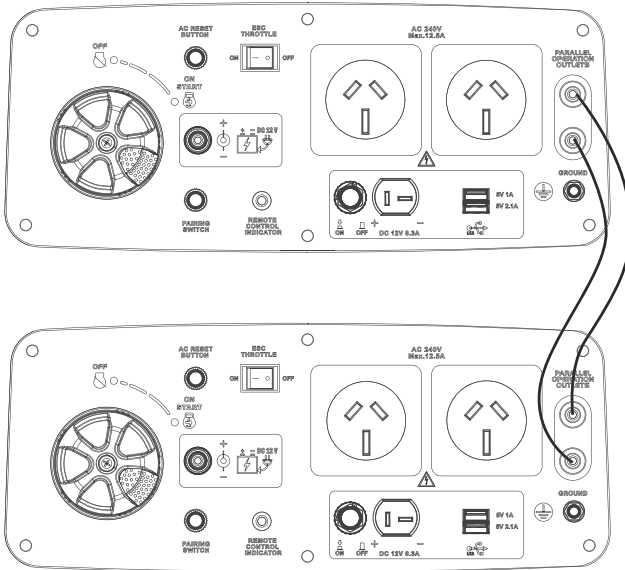

Instructions: First, connect the 2 inverters with 2 parallel cables as per the drawing above, and then start the inverters one at a time. At this time, the total rated power will be 5400W. The parallel cables must be connected to parallel outlet with the same color for each inverter.

Note: Ensure the cables are connected to the inverters correctly. If they are connected incorrectly, the inverters will not output any power and will need to be switched off and then on again after they are correctly connected. **DO NOT** connect or disconnect the parallel cables while the engine is running









**BE**

**THE POWER YOU NEED.**

---