



L3000i(E)
INVERTER
GENERATOR

OPERATION MANUAL



TABLE OF CONTENTS

Safety

- 4 Introduction
- 5 Safety Warnings
- 6 Safety Information

Control Function

- 9 Description
- 9 Control Panel
- 10 3 in 1 Switch Knob
- 10 Engine Smart Control
- 11 Digital Display Meter
- 11 Oil Warning Light
- 12 Overload Indicator Light (Red)
- 12 AC Pilot Light (Green)
- 13 DC Protector
- 13 Ground (Earth) Terminal
- 13 Parallel Operation Outlets
- 13 Brake

Pre-Operation

- 14 Fuel
- 15 Engine oil

Operation

- 16 Operation
- 16 Starting the engine
- 17 Stopping the engine
- 18 Alternating Current (AC) connection
- 19 Battery Charging
- 20 AC Parallel Operation
- 21 AC Parallel Operation Applications
- 22 Application Range

TABLE OF CONTENTS



Maintenance

- 24 Maintenance
- 24 Maintenance Chart
- 26 Spark Plug Inspection
- 26 Carburetor Adjustment
- 27 Clean Fuel Filter
- 27 Engine Oil Replacement
- 28 Air Filter
- 28 Muffler Screen

Storage

- 30 Drain the Fuel
- 30 Engine

Troubleshooting

- 31 Engine Can't Start
- 31 Generator Won't Produce Power

Parameters

- 32 Parameters

Wiring Diagram

- 33 120V

240V



Attention: Read through the complete manual prior to the initial use of your generator.

Using the Operator's manual

The operating manual is an important part of your generator and should be read thoroughly before initial use, and referred to often to make sure adequate safety and service concerns are being addressed.

Reading the owner's manual thoroughly will help avoid any personal injury or damage to your machine. By knowing how best to operate this machine you will be better positioned to show others who may also operate the unit.

This manual contains information for the complete range of BE generators, and was written to take you from the safety requirements to the operating functions of your machine. You can refer back to the manual at any time to help troubleshoot any specific operating functions, so store it with the machine at all times.

Save these Instructions

SAFETY WARNINGS



This is the safety alert symbol. It is used to alert you to potential personal injury hazards. Obey all safety messages that follow this symbol to avoid possible injury or death.

The safety alert symbol () is used with a signal word (DANGER, CAUTION, WARNING), a pictorial and/or a safety message to alert you to hazards.

DANGER you WILL be KILLED or SERIOUSLY HURT if you don't follow instructions.

WARNING you CAN be KILLED or SERIOUSLY HURT if you don't follow instructions.

CAUTION you CAN be HURT if you don't follow instructions



NOTICE your generator or other property could be damaged if you don't follow instructions.

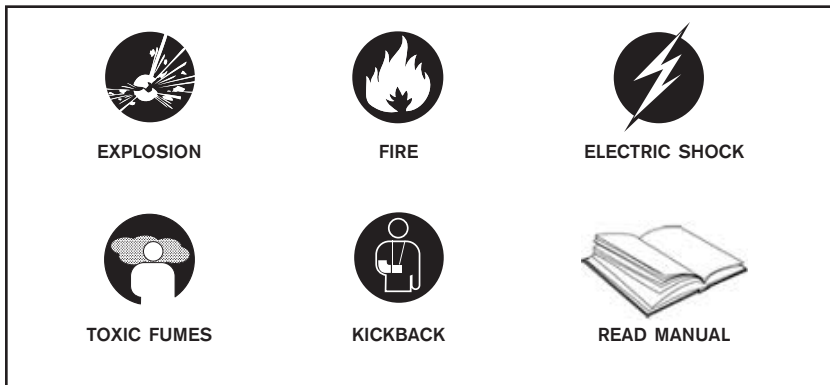

Hazard Symbols and Meanings



SAFETY INFORMATION

Read and understand this owner's manual before operating your generator. It will help you avoid accidents if you get familiar with your generator's safe operation procedures.

 DANGER	
	Do not use indoors.

 DANGER	
	Keep the machine clean and avoid spilling combustibles including gasoline on it.

 WARNING	
	Do not use in a wet condition.

 WARNING	
<ul style="list-style-type: none">▪ Turn the generator "OFF" when adding fuel.▪ Don't add fuel near the flammable thing or cigarette.▪ Keep children and pets away from the area of operation. Do not place flammable objects close to the exhaust when generator operation. Keep it at least 1m away from inflammables.▪ The generating set must not be connected to other power sources, such as the power company supply main. Protection against electrical shock depends on circuit breaker specially matched to the generating set. Due to high mechanical stresses only, tough rubber sheathed flexible cable (in accordance with ICE 245 or the equivalent) should be used. When using extension lines or mobile distribution networks the total length of lines for a cross section of 1.5 mm should not exceed 60 m; for a cross section of 2.5 mm this should not exceed 100 m. Electrical equipment (including lines and plug connections) should not be defective.▪ Utilize safe proper grounding. Use the ground wire with enough electric flux. Ground wire diameter: 0.12mm/A.▪ The generator surface has high temperature, avoid scalding. Pay attention to the warnings on the generating set.	

CONNECTION TO A HOME POWER SUPPLY

If the generator is to be used as standby home power supply the connection is to be performed by a qualified electrician. When loads are connected to the generator, carefully check whether electrical connections are safe and reliable. Any improper connection may cause damage to the generator or cause a fire.

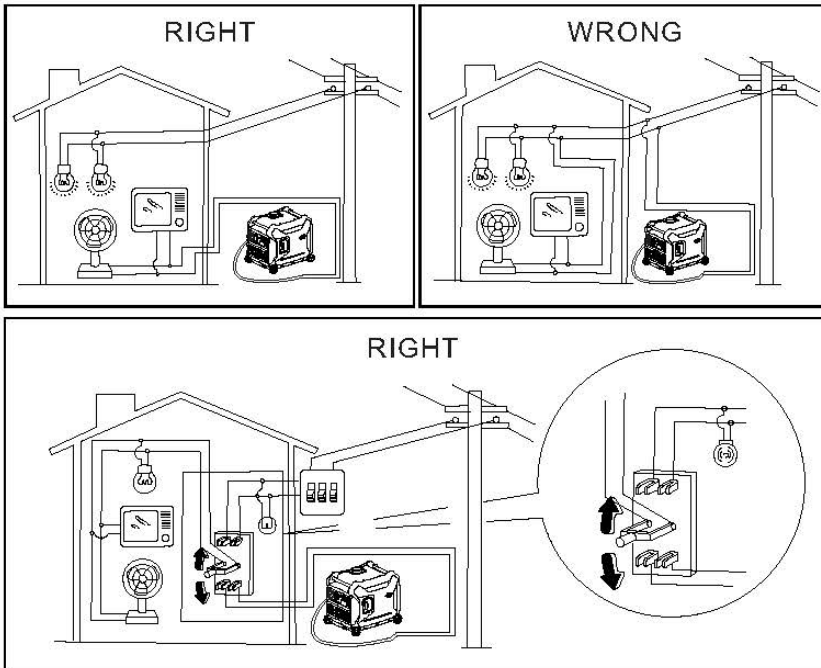

- Keep generator at least 3ft (1m) away from buildings or other structures.
- Only operate generators in a dry, well ventilated area.
- Keep exhaust pipe clear of foreign objects.
- Keep generator away from open flame. No Smoking!
- Keep generator on a stable and level surface.
- Do not block generator air vents with paper or other material.

DO NOT place any heavy objects on the generator. Select and place the generator in the proper position of the transport vehicle so that the generator will not move or fall down. Secure the generator if necessary.

UNIT SAFETY SYMBOLS

There is the warning label on the machine to remind you of the safety regulations.



SYMBOLS	
	Read the safety instructions before using the generator.
	Only fill the generator in well-ventilated areas and keep it away from open flames sparks and cigarettes Spilled fuel should be soaked up immediately. Switch off the engine and let it cool down before filling the generator Fuel is easily flammable and may even explode under certain circumstances.
	Gases such as carbon monoxide (colourless and odorless gas) are produced during operation which may lead to suffocation. Only use the generator in well ventilated areas.
	Warning! Dangerous voltages are present when the generator is in operation. Generator must always be switched off before performing maintenance works.
	Wear ear protection when operating the generator.
	Disconnect all devices from the connections before performing maintenance work before leaving the device and after switching it off.
	The generator may not be connected to the public power supply When the device is falsely connected there is a risk of fire material damage and even a fatal electric shock being suffered by the operator as is also the case when performing works on the public power supply.

Control Function DESCRIPTION

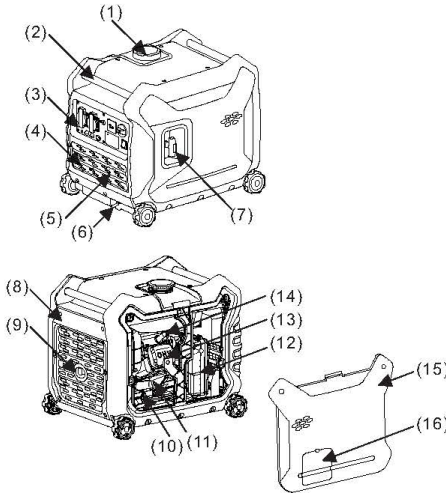

1. Fuel tank cap
2. Handle
3. Control panel
4. Inverter parts
5. Battery
6. Brake
7. Recoil starter grip
8. Shutter
9. Muffler
10. Oil drain bolt
11. Oil filler cap
12. Air cleaner
13. Carburetor
14. Spark plug
15. Left cover
16. Oil observation window

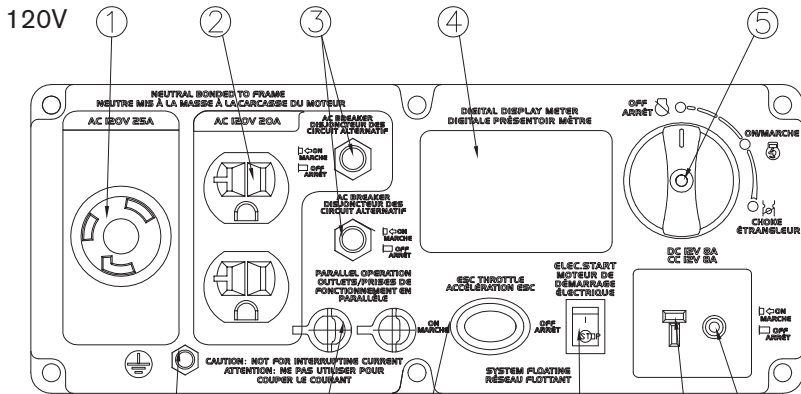

CONTROL PANEL

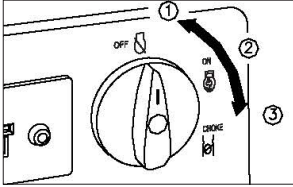

面板需换成240V，澳式插座状态

1. AC receptacle
2. AC receptacle
3. AC circuit breaker
4. Multimeter
5. 3 in 1 switch knob
6. DC protector
7. DC receptacle
8. Electric Start
9. ESC (engine start control)
10. Parallel receptacle
11. Ground terminal

3 IN 1 SWITCH KNOB

1. Engine/fuel valve  "OFF"; Ignition circuit is switched off. Fuel is switched off. The engine will not run.
2. Engine switch\fuel valve choke.  "ON" Ignition circuit is switched on. Fuel is switched on. Choke is switched on. The engine will run.
3. Engine switch\fuel valve\choke.  "ON" Ignition circuit is switched on. Fuel is switched on. Choke is switched on. The engine can be start.

TIP: The choke  is not required to start a warm engine

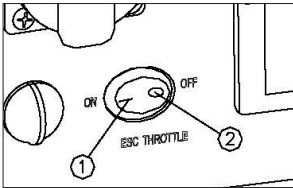
ENGINE SMART CONTROL

1. "ON"
When the ESC switch is turned to "ON", the economy control unit controls the engine speed according to the connected load. The results are better fuel consumption and less noise.
2. "OFF"
When the ESC switch is turned to "OFF", the engine runs at the rated (3100r/min) Regard-less of whether is a load connected or not.

TIP: The choke is not required to start a warm engine

DIGITAL DISPLAY METER

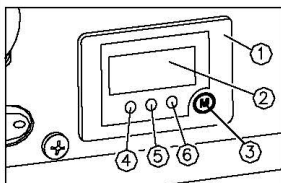

1. Multimeter
2. Liquid crystal display
3. Operating key
4. Oil warning light
5. Overload indicator light
6. AC pilot light

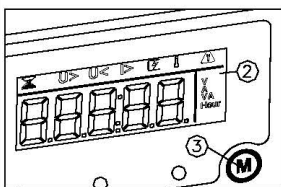

Liquid crystal display

Normal Operation:

During the normal operation, the operation key (3) for switching the display cycle showing: voltage current power-cycle accumulative time current time.

In case of failed operation:

- U> a: AC over voltage, indicating the character of AC (alternative indication of AC and digit)
- b: DC over voltage, indicating the character of DC (alternative indication of DC and digit)
- U< a: AC under-voltage, indicating the character of AC (alternative indication of AC and digit)
- b: DC under-voltage, indicating the character of DC (alternative indication of DC and digit)

I> Output over current of generator

Output short circuit of generator

Over heat of generator

Maintenance time

OIL WARNING LIGHT

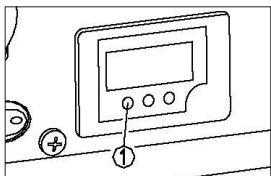

When the oil level falls below the lower level, the oil warning light comes on and then the engine stops automatically. Unless you refill with oil, the engine will not start again.

TIP: If the engine stalls or does not start, turn the engine switch to "ON" and then pull the recoil starter. If the oil warning light flickers for a few seconds, the engine oil is insufficient. Add oil and restart.

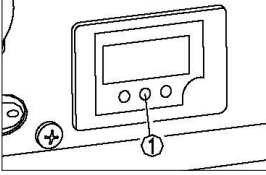
OVERLOAD INDICATOR LIGHT (RED)

The overload indicator light comes on when an overload of a connected electrical device is detected, the inverter control unit overheats, or the AC output voltage rises. Then, the AC protector will trip, stopping power generation in order to protect the generator and any connected electric devices. The AC pilot light (Green) will go off and the overload indicator light (Red) will stay on, but the engine will not stop running. When the overload indicator light comes on and power generation stops, proceed as follows:

1. Turn off any connected electric devices and stop the engine.
2. Reduce the total wattage of connected electric devices within the rated output.
3. Check for blockages in the cooling air Inlet and around the control unit. If any blockages are found remove.
4. After checking, restart the engine.

TIP: The overload indicator light may come on for a few seconds at first when using electric devices that require a large starting current, such as a compressor or a submersible pump. However, this is not a malfunction.

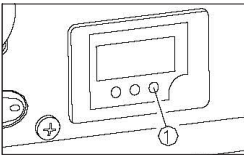
AC PILOT LIGHT (GREEN)

The AC pilot light comes on when the engine starts and produces power.

DC PROTECTOR

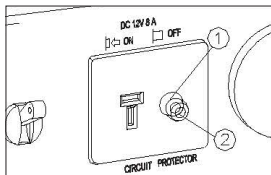

The DC protector turns to “OFF” automatically when electric device being connected to the generator is operating and current above the rated flows. To use this equipment again, turn on DC protector by pressing its button to “ON”.

1. “ON” Direct current is output.
2. “OFF” Direct current is not output.

NOTICE

- Reduce the load of the connected electric device below the specified rated output of the generator if the DC protector turns off. If the DC protector turns off again, stop using the device immediately and consult a franchised dealer.

GROUND (EARTH) TERMINAL

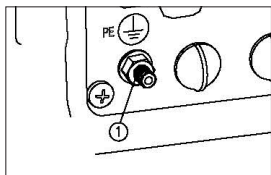

Ground (Earth) terminal (1) connects the earth line for prevention of electric shock. When the electric device is earthed, always the generator must be earthed.

PARALLEL OPERATION OUTLETS

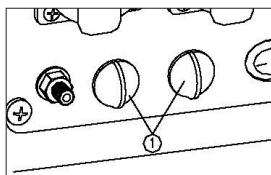

This is the terminal for connecting special cables for parallel running of two generator. The parallel running requires two generator and the special cables. (The rated output in parallel running is 6.0Kva and the rated current is 60A/100V;50A/120V;26A/230V.)

The handing, operation procedure and the notes on usage are described in the PARALLEL RUNNING KIT OWNER'S MANUAL included in the Parallel.

25A/240V

BRAKE

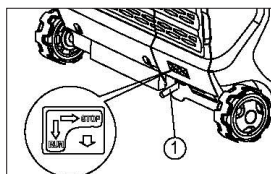

During the operation and idle period of machine, brake timely and switch to “STOP”. In case of the machine is required to be moved, switch the brake to “RUN”.

Pre-Operation

NOTICE

- Pre-operation checks should be made each time operation.

⚠ WARNING

- The engine and muffler will be very hot after the engine has been run. Avoid touching the engine and muffler while they are still hot with any part of your body or clothing during inspection or repair.

FUEL

⚠ WARNING

- Fuel is highly flammable and poisonous. Check "SAFETY INFORMATION"(See page 2-5) carefully before filling.
- Do not overfill the fuel tank, otherwise it may overflow when the fuel warms up and expands. After filling the fuel, make sure the fuel tank cap is tightened securely.
- Immediately wipe off spilled fuel with a clean.
- Use only unleaded gasoline. The use of leaded gasoline
- Will cause severe damage to internal engine parts.

Make sure enough gasoline is in the fuel tank.

Recommended fuel: Unleaded gasoline | Fuel tank capacity: Total: 10.0L

1. Fuel level gauge

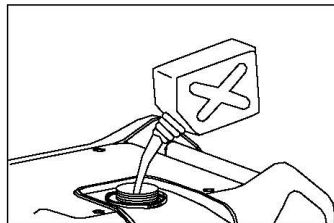
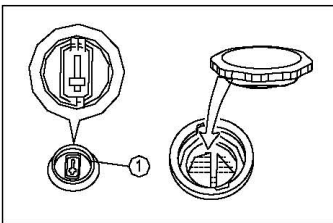

ENGINE OIL

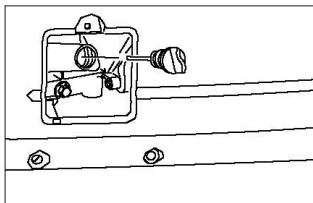

The generator has been shipped without engine oil. Do not start the engine until filled with the sufficient engine oil. Do not tilt the generator when adding engine oil. This could result in overfilling and damage to the engine.

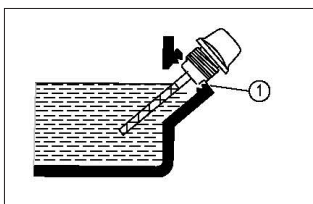

Recommended engine oil: SAE 10W -30
Recommended engine oil grade:
API Service SE type or higher
Engine oil quantity: 0.6 L

Operation

NOTICE

- Never operate the engine in a closed area or it may cause unconsciousness and death within a short time. Operate the engine in a well ventilated area. The generator has been shipped without engine oil. Do not start the engine until filled with the sufficient engine oil.

TIP:

- The generator can be used with the rated output load at standard atmospheric conditions.
- “Standard atmospheric conditions ”; Ambient temperature 25.
- Barometric pressure 100kPa; Relative humidity 30%
- The output of the generator varies due to change temperature, altitude (lower air pressure at higher altitude) and humidity.
- The output of the generator is reduced when the temperature, the humidity and the altitude are higher than standard atmospheric conditions.
- Additionally, the load must be reduced when using in confined areas, as generator cooling is affected.

STARTING THE ENGINE

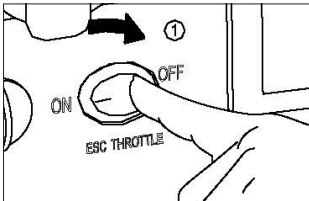

Before starting the engine, do not connect any electric devices.

Turn the ESC switch to “OFF” (1)

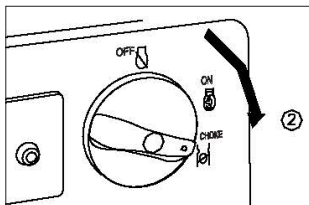

Turn the 3 in 1 switch to “CHOKE”

- a. Ignition circuit is switched on.
- b. Fuel is switched on.
- c. Choke is switched off.

TIP: The choke is not required to start a warm engine. Push the choke knob in to the position “ON”.

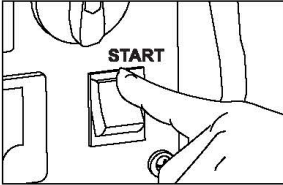

Electric Start

Turn the engine switch on the control panel to ON Or press it to START if it is electrical start state then generator unit can be started In order to extend the service life of the storage battery do not press on the switch for more than 3 seconds and the interval between two pressings should be longer than 10 seconds.

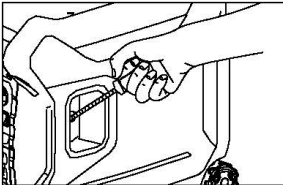

Recoil Start

Grasp the carrying handle firmly to prevent the generator from falling over when pulling the recoil starter.

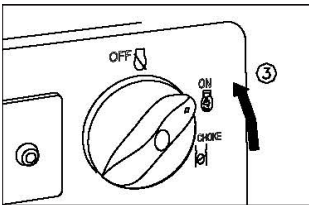

After the engine starts, warm up the engine until the engine does not stop when the choke knob is returned to the “ON” position. (3)

TIP:

When starting the engine, with the ESC “ON” and there is no load on the generator: In ambient temperature below 0°C (32°F), the engine will run at the rated (3600r/min) for 5 minutes to warm up the engine. In ambient temperature below 5°C (41°F), the engine will run at the rated r/min (3600r/min) for 3 minutes to warm up the engine. The ESC unit operates normally after the above time period, while the ESC is “ON”.

STOP THE ENGINE

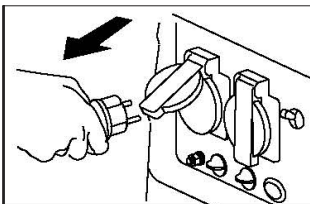

Release the load.

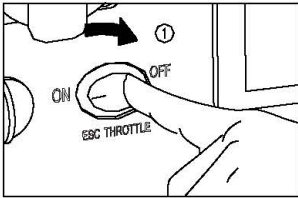

- TIP:** Turn off any electric devices.
1. Disconnect any electric devices.
 2. Turn the ESC to "OFF" (1).
 3. Turn the 3 in 1 switch to "OFF" (2).
 - a. Ignition circuit is switched off.
 - b. Fuel valve is switched off.

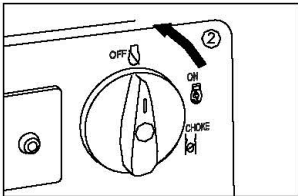

ALTERNATING CURRENT (AC) CONNECTION

WARNING

- Be sure any electric devices are turned off before plugging them in.

NOTICE

- Be sure all electric devices including the lines and plug connections are in good condition before connection to the generator.
- Be sure the total load is within generator rated output.
- Be sure the receptacle load current is within receptacle rated current.

TIP: Make sure to ground (Earth) the generator. When the electric device is earthed, always the generator must be earthed.

1. Start the engine.
2. Turn the ESC to "ON".
3. Plug in to AC receptacle.
4. Make sure the AC pilot light is on.
5. Turn on any electric devices.

TIP: The ESC must be turned to "OFF" before increasing engine speed to rated rpm.

- Most motorized appliances require more than their electrical rating for startup. When an electrical motor is started, the overload indicator (red) may come on. This is normal if the overload indicator (red) goes off within 4 seconds. If the overload indicator (red) stays on, consult your generator dealer.
- If the generator is connected to multiple loads or electricity consumers, please remember to first connect the one with the highest starting current. And last connect the one with the lowest starting current.

- If the generator is overloaded, or if there is a short circuit in a connected appliance, the overload indicator (red) will go ON. The overload indicator (red) will stay ON, and after about 4 seconds, the connected appliance(s) will shut off, and the output indicator (green) will go OFF. Stop both engines and investigate the problem. Determine if the cause is a short circuit in a connected appliance or an overload, correct the problem and restart the generator.

BATTERY CHARGING

TIP:

- The generator DC rated voltage is 12V.
- Start the engine first, and then connect the generator to the battery for charging.
- Before starting to charge the battery, make sure that the DC protector is turned on.

1. Start the engine.
2. Connect the red battery charger lead to the positive (+) battery terminal.
3. Connect the black battery charger lead to the negative (-) battery terminal.
4. Turn the ESC "OFF" to start battery charging.

NOTICE

- Be sure the ESC is turned off while charging the battery.
- Be sure to connect the red battery charger lead to the positive (+) battery terminal, and connect the black lead to the negative (-) battery terminal. Do not reverse these positions.
- Connect the battery charger leads to the battery terminals securely so that they are not disconnected due to engine vibration or other disturbances.
- Charge the battery in the correct procedure by following instructions in the owner's manual for the battery.
- The DC protector turns off automatically if current goes above the rated flow during battery charging. To restart charging the battery, turn the DC protector on by pressing its button to "ON". If the DC protector turns off again, stop charging the battery immediately and consult a servicing dealer.

TIP:

- Follow instructions in the owners manual for the battery to determine the end of battery charging.
- Measure the specific gravity of electrolyte to determine if the battery is fully charged. At full charge, the electrolyte specific gravity is between 1.26 and 1.28.
- It is advisable to check the specific gravity of the electrolyte at least once every hour to prevent overcharging the battery.

 **WARNING**

- Never smoke or use broken connectors on the battery while charging. Sparks may ignite the battery gas.
- Battery electrolyte is poisonous and dangerous, causing severe burns, etc. contains sulfuric (sulphuric) acid. Avoid contact with skin, eyes or clothing.
- Antidote:
EXTERNAL: Flush with water.
INTERNAL: Drink large quantities of water or milk. Follow with milk of magnesia, beaten egg or vegetable oil . Call physician immediately.
- **EYES:** Flush with water for 15 minutes and get prompt medical attention.
- Batteries produce explosive gases. Keep sparks, flame, cigarettes, etc., away. Ventilate when charging or using in closed space. Always wear eye protection when working near batteries.
- Keep out of reach of children.

AC PARALLEL OPERATION

Before connection an appliance to either generator, make sure that it is in good working order and that its electrical rating does not exceed that of the receptacle.

During parallel operation, the ESC switch should be in the same position on both generators.

1. Connect the parallel operation cable between the generator to either the main generator or companion generator following the instructions supplied with the cable kit.
2. Start the engines and make sure the output indicator (green) on each generator comes on.
3. Plug an appliance into the AC receptacle.
4. Turn on the appliance.

AC PARALLEL OPERATION APPLICATIONS

TIP:





- Make sure that it is in good working order. A faulty appliance or power cord can create a potential for electrical shock.
- If an appliance begins to operate abnormally, becomes sluggish, or stops suddenly, turn it off immediately. Disconnect the appliance and determine whether the problem is the appliance, or the rated load capacity of the generator has been exceeded.
- Make sure that the combined electrical rating of the tools or appliance does not exceed that of the generator.
- Never connect different generator models.
- Don't remove the parallel operation cable when the generator operation.
- For single generator operation, the parallel operation cable must be removed.

**WARNING**

- Substantial overloading that continuously lights the overload indicator (red) may damage the generator. Marginal overloading that temporarily light the overload indicator (red) may shorten the service life of the generator.
- For continuous operation, do not exceed the rated power.
- Rated power in parallel operation is: 6KW.

APPLICATION RANGE

When using the generator, make sure the total load is within rated output of a generator. Otherwise, generator damage may occur.

AC				DC 
Power Factor	1	0.8-0.95	0.4-0.75 (Efficiency 0.85)	
L3000i(E)	~3,000W	~2,400W	~1,200W	Rated voltage 12V Rated current 8A

TIP:

- Application wattage indicates when each device is used by itself.
- The simultaneous usage of AC and DC power is possible but total wattage should not exceed the rated output.

EX:

Generator rated output		3,000V A
Frequency	Power factor	
AC	1.0	~3,000W
	0.8	~2,400W
DC	---	96W (12V/8A)

NOTICE

- Do not overload. The total load of all electrical appliances must not exceed the supply range of the generator. Overloading will damage the generator.
- When supplying precision equipment, electronic controllers, PCs, electronic computers, microcomputer based equipment or battery chargers, keep the generator a sufficient distance away to prevent electrical interference from the engine. Also ensure that electrical noise from the engine does not interfere with any other electrical devices located near the generator.
- If the generator is to supply medical equipment, advice should first be obtained from the manufacturer, a medical professional or hospital.
- Some electrical appliances or general-purpose electric motors have high starting currents, and cannot therefore be used, even if they lie within the supply ranges given in the above table. Consult the equipment manufacturer for further advice.

Maintenance

Safety is an obligation of the owner. Periodic inspection, adjustment and lubrication will keep your generator in the safest and most efficient condition possible. The most important points of generator inspection and lubrication are explained on the following pages.

⚠ WARNING

- If you are not familiar with maintenance work, have a servicing dealer do it for your safety.

MAINTENANCE CHART

Use only servicing dealer specified genuine parts for replacement. Ask an authorized servicing dealer for further attention.

⚠ WARNING

- Stop the engine before starting maintenance work.

Item	Routine	Pre-operation check (daily)	6 Months / 100 Hours	12 Months / 300 Hours
Spark Plug	Check condition. Clean and replace if necessary.	X		
Fuel	Check fuel level and leakage.	X		
Fuel Hose	Check fuel hose for cracks or damage, Replace if necessary.	X		
Oil	Check oil level in engine.	X		
	Replace.		x (1)	
Air Filter	Check condition. Clean and replace if necessary.		x (2)	
Muffler Screen	Check condition. Clean and replace if necessary.		X	
Spark Arrester	Check condition. Clean and replace if necessary.		X	
Fuel Filter	Clean and replace if necessary.			X

Item	Routine	Pre-operation check (daily)	6 Months / 100 Hours	12 Months / 300 Hours
Crankcase breather hose	Check hose weather for cracks or damage. Replace if necessary.			X
Cylinder head	Decarbonizes cylinder head. More frequently if necessary.			*
Valve clearance	Check and adjust when engine is cold			*
Fittings/ fasteners	Check all fittings and fasteners. Correct if necessary.			*
The point where abnormality was recognized by use		X		

- (1) Initial replacement of the engine oil is one month or after 20 hours of operation.
 - (2) The air filter needs to be cleaned more frequently when using in unusually wet or dusty areas.
- * Since these items require tools, and technical skills, you should find a local dealer perform the service.

SPARK PLUG INSPECTION

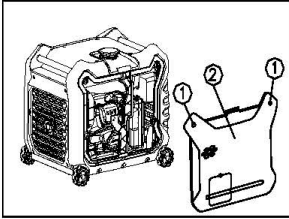

The spark plug is important engine components, which should be checked periodically.

1. Unscrew and take off the left exterior cover.
2. Remove the noise suppressor cap assy install spark plug box wrench on the spark plug appropriately.
3. Insert the handlebar in to the tool and turn it counterclockwise to remove the spark plug.
4. Check for discoloration and remove the carbon. The porcelain insulator around the center electrode of spark plug should be a medium-to- light tan color.
5. Check the spark plug type and gap. Standard spark plug: BPR6ES/BP6ES GK F7RTC F7TC
Spark plug gap: 0.6-0.7mm
6. Install the spark plug.

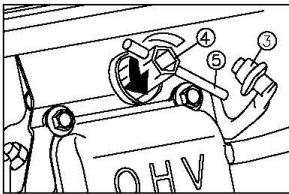

TIP: If a torque wrench is not available when installing a spark plug, a good estimate of the correct torque is 1/4-1/2 turn past finger tight. However, the spark plug should be tightened to the specified torque as soon as possible.

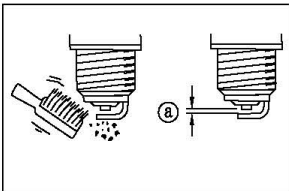

7. Install the spark plug cap and spark plug cover.

CARBURETOR ADJUSTMENT

The carburetor is a vital part of the engine. Adjusting should be left to a dealer with the professional knowledge, specialized tools, and equipment to do so properly.

CLEAN FUEL FILTER

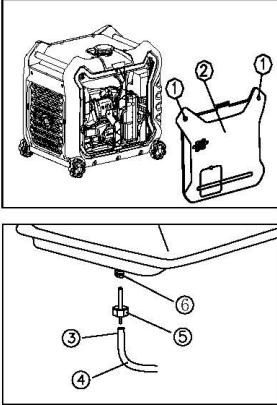

1. Unscrew the screw (1) and take off the left exterior cover (2).
2. Drain the fuel in the fuel tank. Hold the tube clip (3) toward downward and pull out the fuel tube (4) which is connected to the fuel tank, then disassemble fuel filter.
3. Put the fuel filter (5) into noncombustible or higher flash point solvent and clean it.
4. Assemble fuel filter to the main jet (6) on the fuel tank then install tube clip.

ENGINE OIL REPLACEMENT

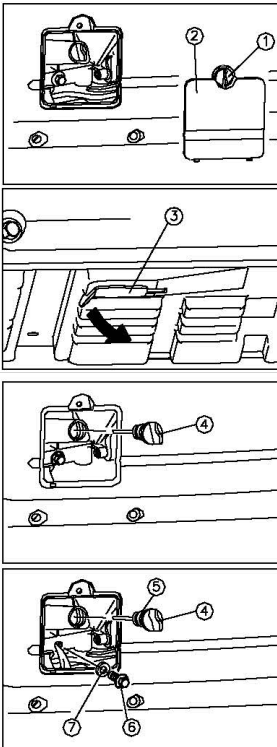

Avoid draining the engine oil immediately after stopping the engine. The oil is hot and should be handled with care to avoid burns.

1. Place the generator on a level surface and warm up the engine for several minutes.
2. Unscrew the screw (1) and take off the sight glass of engine oil (2).
3. Lift and tilt the machine; take off the end cap (3) at the bottom plate of machine
4. Remove the oil filler cap.
5. Place an oil pan under the engine, remove the oil drain bolt (6) drain the oil from the oil tank.
6. Check oil filler cap (4), O-ring (5), Oil drain bolt (6), Oil filler cap packing (7). Replace immediately with new components if any are damaged.
7. Assemble oil drain bolt and oil filler cap packing.
8. Add oil to a suitable level, tighten oil filler cap.
9. Assemble the end cap at the bottom of machine .
10. Assembly the sight glass of engine oil.

NOTICE

- Do not tilt the generator when adding engine oil. This could result in overfilling and damage to the engine. Don't allow foreign objects to fall into engine.
- Oil and gasoline could pollute the environment, don't throw it in the trash or pour it on the ground.

AIR FILTER

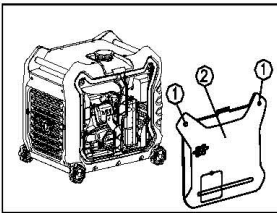

1. Unscrew the screw (1) and take off the left exterior cover (2).
2. Remove the air filter cover and foam element (3).
3. Wash the foam element in solvent and dry it.
4. Add oil to the foam element and squeeze out excess oil. The foam element should be wet but not dripping, to avoid damage.
5. Insert the foam element into the air filter case.

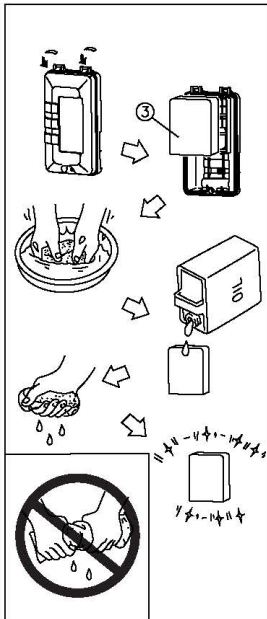

6. Install the air filter case cover in its original position.
- TIP:** Be sure the foam element sealing surface matches the air filter so there is no air leak. The engine should never run without the air filter; excessive poisonous gas will lead to piston and cylinder wear.

MUFFLER SCREEN

WARNING

- The engine and muffler will be very hot after the engine has been run. Avoid touching the engine and muffler while they are still hot with any part of your body or clothing during inspection or repair.

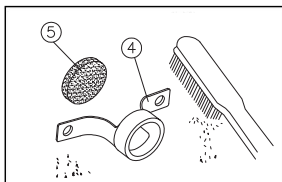
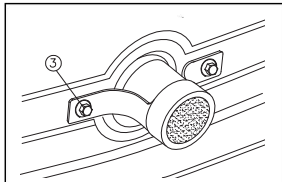
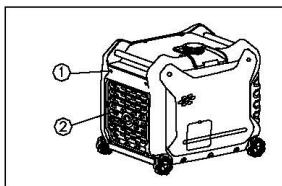

1. Unscrew 6 bolts (1) and take off shutter (2).
2. Remove the muffler screen (4,5), and remove the bolt (3).
3. Clean the carbon on the muffler screen with a wire brush.
4. Check the muffler screen and spark arrester, replace if it damaged.
5. Install spark arrester.

WARNING

- Never use an engine without an appropriate spark arrester in the forest areas! Doing so may cause a fire!

Storage

Long term storage of your machine will require some preventive procedures to guard against deterioration.

DRAIN THE FUEL

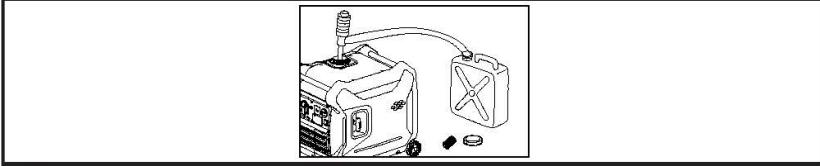

1. Turn the 3 in 1 switch to "OFF".
2. Remove the fuel tank cap, remove the filter. Extract the fuel from the fuel tank into an approved gasoline container using a commercially available hand siphon. Then, install the fuel tank cap.
3. Fuel is highly flammable and poisonous. Check "SAFETY INFORMATION" carefully immediately wipe off spilled fuel with a clean, dry, soft cloth, since fuel may deteriorate painted surfaces or plastic parts.
4. Start the engine and leave it running until it stops. The engine will stop in approx. 20 mins, when it has run out of fuel.

TIP:

- Do not connect with any electrical devices. (Unloaded operation).
 - Duration of the running engine depends on the amount of the fuel left in the tank.
5. Drain the fuel from the carburetor by loosening the drain screw on the carburetor float chamber.
 6. Turn the 3 in 1 switch to "OFF".
 7. Tighten the drain screw.

ENGINE

Perform the following steps to protect the cylinder, piston ring, etc. from corrosion.

1. Remove the spark plug; pour about one table-spoon of SAE 10W-30 into the spark plug hole and reinstall the spark plug.
2. Recoil start the engine by turning over several times (with 3 in 1 switch knob off) to coat the cylinder walls with oil.
3. Pull the recoil starter until you feel compression. (This prevents the cylinder and valves from rusting).
4. Then stop pulling.
5. Clean the outside of engine and spay antirust additive.
6. Store the generator in a dry, well-ventilated place, with the cover placed over it.
7. Store the engine vertically.

Troubleshooting

ENGINE CAN'T START

1. Fuel Systems
 - No gasoline in the combustion chamber.
 - No fuel in the fuel tank...add fuel.
 - Fuel in tank.
 - Clogged fuel filter Clean fuel filter.
 - Clogged carburetor.... Clean carburetor.
2. Engine Oil System
 - Oil level is low.... Add engine oil.
3. Electrical Systems
 - Put the 1 in 3 switch to "CHOKE" and pull the recoil starter...Poor spark.
 - Spark plug dirty with carbon or wet.... Remove carbon or wipe spark plug dry.
 - Faulty ignition system.... Consult a franchised dealer.

GENERATOR WON'T PRODUCE POWER

- Safety device (DC protector) to "OFF".... Press the DC protector to "ON".
- The AC pilot light (Green) goes off Stop the engine, and then restart.

Parameters

	Item	L3000i(E) Generator	
Generator	Type	Inverter	
	Rated frequency (Hz)*	60 50	
	Rated voltage (v)*	120 240	
	Rated output power (kW)	3.0	
	Max output power (kW)	3.3	
	Power Factor	1	
	AC output quality	ISO8528 G2	
	THD/%	≤5	
	Noise Level dB/LpA/ LwA/K 4m (1/4 load)	60	
	DC Output/ V-A	12-8	
	Overload Protect	DC	Non-fuse Protector
		AC	Control by inverter overload protect program
Engine	Engine	Powerease	
	Engine type	Single cylinder, 4-stroke, forced air cooling, OHV	
	Displacement (cc)	212	
	Fuel type	Unleaded Gasoline	
	Fuel tank capacity (L)	10	
	Continue Running Time (at rated power)(h)	5.5	
	Oil Tank Capacity (L)	0.6	
	Spark Model No.	BPR6ES/BP6ES(NGK) F7RTC/F7TC	
	Starting mode	Recoil Start/Electric Start	
Generator set	Length x Width x Height (mm)	579 × 440 × 510	
	Net weight (kg)	45	

WIRING DIAGRAM



Wiring Diagram

120V

240V 电路图需更换

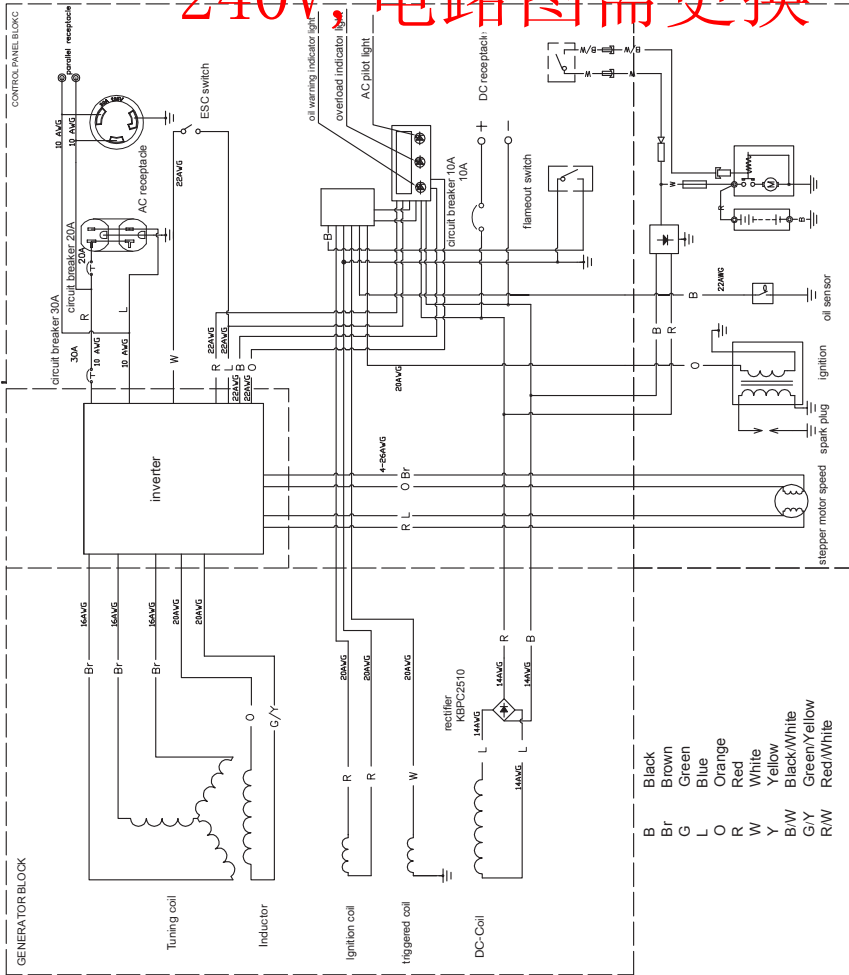



**Distributed in Australia:
BAR Group
15 Hudson Place
Mulgrave, NSW 2756**

**Distributed in New Zealand:
BE Pressure Supply Limited
8 Perclo Place
Te Rapa (Saint Andrews) 3200**

